

EN - Refrigerating air dryer

SACT 600 - 5000

ENGLISH



EN - User's maintenance and spare parts manual

SCHULZ

Dear Customer

thank you for choosing our product. In order to get the best performances out of this product, please read this manual carefully.

To avoid incorrect operation of the equipment and possible physical risk to the operator, please read and strictly follow the instructions contained in this manual.

Note, these instructions are in addition to the safety rules that apply in the country where the dryer is installed.

Before packing for shipment each **SACT** series refrigerated air dryer undergoes a rigorous test to ensure the absence of any manufacturing faults and to demonstrate that the device can perform all the functions for which it has been designed.

Once the dryer has been properly installed according to the instructions in this manual, it will be ready for use without any further adjustment. The operation is fully automatic, and the maintenance is limited to few controls and some cleaning operations, as detailed in the following chapters.

This manual must be maintained available in any moment for future references and it has to be intended as inherent part of the relevant dryer.

Due to the continuous technical evolution, we reserve the right to introduce any necessary change without giving previous notice.

Should you experience any trouble, or for further information, please do not hesitate to contact us.

Contents

1	Identification plate	5
2	Warranty conditions	5
3	Safety rules	5
3.1	Definition of the conventional signs used in this manual	5
3.2	Warnings	7
3.3	Proper use of the dryer	7
3.4	Instructions for the use of pressure equipment according to PED directive 2014/68/EU	8
4	Installation	8
4.1	Transport	8
4.2	Storage	8
4.3	Installation site	9
4.4	Installation layout	10
4.5	Correction factors	11
4.6	Connection to the compressed air system	12
4.7	Connection to the cooling water network (Water-Cooled)	12
4.8	Electrical connections	13
4.9	Condensate drain	14
5	Start-up	14
5.1	Preliminary operation	14
5.2	First start-up	15
5.3	Start-up and shut down	16
6	Technical data	17
6.1	Technical data SACT 600 – 5000 3/460/60	17
6.2	Technical data SACT 600 – 5000 3/380/60	18
7	Technical description	19
7.1	Control panel	19
7.2	Operation	19
7.3	Flow diagram (Air-Cooled)	20
7.4	Flow diagram (Water-Cooled)	20
7.5	Refrigerating compressor	21
7.6	Condenser (Air-Cooled)	21
7.7	Condenser (Water-Cooled)	21
7.8	Condenser water regulating valve (Water-Cooled)	21
7.9	Filter dryer	21
7.10	Capillary tube	22
7.11	Alu-Dry module	22
7.12	Hot gas by-pass valve	22
7.13	Refrigerant pressure switches LPS – HPS	23
7.14	Compressor crankcase heater	23
7.15	Electronic instrument DMC24	24
7.15.1	How to switch on the dryer	25
7.15.2	How to switch off the dryer	25
7.15.3	How to display the operating parameters – INFO Menu	25
7.15.4	How a service warning is displayed	26
7.15.5	How an alarm is displayed	27
7.15.6	How to show the alarm memory – LOG Menu	28
7.15.7	How to control dryer with remote control	28
7.15.8	Operation of the failure / alarm dry contact (potential free)	28
7.15.9	Connection to serial line	28
7.15.10	How to change operating parameters – SETUP Menu	29
7.16	Electronic drainer	30
8	Maintenance, troubleshooting, spare parts and dismantling	31
8.1	Checks and maintenance	31
8.2	Troubleshooting	32
8.3	Spare parts	37
8.4	Maintenance operation on the refrigeration circuit	39
8.5	Dismantling of the dryer	39
9	Attachments	40

Exploded views – List of components	40
Electric diagrams – List of components	40
9.1 Dryers dimensions	41
9.1.1 SACT 600 – 1250	41
9.1.2 SACT 1500 – 2500	42
9.1.3 SACT 3000 - 3750	43
9.1.4 SACT 4000 – 5000	44
9.2 Exploded views	45
9.2.1 SACT 600 – 1250 Air Cooled	45
9.2.2 SACT 600 – 1250 Water Cooled	46
9.2.3 SACT 1500 – 2500 Air Cooled	47
9.2.4 SACT 1500 – 2500 Water Cooled	48
9.2.5 SACT 3000 – 3750 Air Cooled	49
9.2.6 SACT 3000 – 3750 Water Cooled	50
9.2.7 SACT 4000 – 5000 Air Cooled	51
9.2.8 SACT 4000 – 5000 Water Cooled	52
9.3 Electric diagrams	53
9.3.1 SACT 600 – 1250 Sheet 1 of 3	53
9.3.2 SACT 600 – 1250 Sheet 2 of 3	54
9.3.3 SACT 600 – 1250 Sheet 3 of 3	55
9.3.4 SACT 1500 – 2500 Sheet 1 of 4	56
9.3.5 SACT 1500 – 2500 Sheet 2 of 4	57
9.3.6 SACT 1500 – 2500 Sheet 3 of 4	58
9.3.7 SACT 1500 – 2500 Sheet 4 of 4	59
9.3.8 SACT 3000 – 5000 Sheet 1 of 6	60
9.3.9 SACT 3000 – 5000 Sheet 2 of 6	61
9.3.10 SACT 3000 – 5000 Sheet 3 of 6	62
9.3.11 SACT 3000 – 5000 Sheet 4 of 6	63
9.3.12 SACT 3000 – 5000 Sheet 5 of 6	64
9.3.13 SACT 3000 – 5000 Sheet 6 of 6	65
10 Blank pages	66

1 Identification plate

The identification plate is located on the back of the dryer and shows all the primary data of the machine. This data should always be referred to when calling the manufacturer or distributor. The removal or alteration of the identification plate will void the warranty rights.

2 Warranty conditions

For 12 months from the installation date, but no longer than 14 months from the delivery date, the warranty covers eventual faulty parts, which will be repaired or replaced free of charge, except the travel, hotel and restaurant expenses of our engineer.

The warranty doesn't cover any responsibility for direct or indirect damages to persons, animals or equipment caused by improper usage or maintenance, and it's limited to manufacturing faults only.

The right to warranty repairs is subordinated to the strict compliance with the installation, use and maintenance instructions contained in this manual.

The warranty will be immediately voided in case of even small changes or alterations to the dryer. To require repairs during the warranty period, the data reported on the identification plate must be notified.

3 Safety rules

3.1 Definition of the conventional signs used in this manual



Carefully read instruction manual before attempting any service or maintenance procedures on the dryer.



Caution warning sign. Risk of danger or possibility of damage to equipment, if related text is not followed properly.



Electrical hazard. Warning message indicates practices or procedures that could result in personal injury or fatality if not followed correctly.



Danger hazard. Part or system under pressure.



Danger hazard. High temperature conditions exist during operation of system. Avoid contact until system or component has dissipated heat.



Danger hazard. Treated air is not suitable for breathing purposes; serious injury or fatality may result if precautions are not followed.



Danger hazard: In case of fire, use an approved fire extinguisher, water is not an acceptable means in cases of fire.



Danger hazard. Do not operate equipment with panels removed.



Maintenance or control operation to be performed by qualified personnel only [1].



Compressed air inlet connection point



Compressed air outlet connection point



Condensate drain connection point



Cooling water inlet connection point (Water-Cooled)



Cooling water outlet connection point (Water-Cooled)



Operations which can be performed by the operator of the machine, if qualified [1].

NOTE: Text that specifies items of note to be taken into account does not involve safety precautions.



In designing this unit a lot of care has been devoted to environmental protection:

- CFC free refrigerants
- CFC free insulation parts
- Energy saving design
- Limited acoustic emission
- Dryer and relevant packaging composed of recyclable materials

This symbol requests that the user heed environmental considerations and abide with suggestions annotated with this symbol.

[1] Experienced and trained personnel familiar with national and local codes, capable to perform the needed activities, identify and avoid possible dangerous situations while handling, installing, using and servicing the machine. Ensuring compliance to all statutory regulations.

3.2 Warnings



Compressed air is a highly hazardous energy source.

Never work on the dryer with pressure in the system.

Never point the compressed air or the condensate drain outlet hoses towards anybody.



The user is responsible for the proper installation of the dryer. Failure to follow instructions given in the "Installation" chapter will void the warranty. Improper installation can create dangerous situations for personnel and/or damages to the machine could occur.



Only qualified personnel are authorized to service electrically powered devices. Before attempting maintenance, the following conditions must be satisfied:

- Ensure that main power is off, machine is locked out, tagged for service and power cannot be restored during service operations.
- Ensure that valves are shut and the air circuit is at atmospheric pressure. De-pressurize the dryer.



These refrigerating air dryers contain R407C HFC type refrigerant fluid. Refer to the specific paragraph - maintenance operation on the refrigerating circuit.



Warranty does not apply to any unit damaged by accident, modification, misuse, negligence or misapplication. Unauthorized alterations will immediately void the warranty.



In case of fire, use an approved fire extinguisher, water is not an acceptable means in cases of electrical fire.

3.3 Proper use of the dryer

This dryer has been designed, manufactured and tested for the purpose of separating the humidity normally contained in compressed air. Any other use has to be considered improper.

The Manufacturer will not be responsible for any problem arising from improper use; the user will bear responsibility for any resulting damage.

Moreover, the correct use requires the adherence to the installation instructions, specifically:

- Voltage and frequency of the main power.
- Pressure, temperature and flow-rate of the inlet air.
- Pressure, temperature and cooling water capacity (Water-Cooled).
- Ambient temperature.

This dryer is supplied tested and fully assembled. The only operation left to the user is the connection to the plant in compliance with the instructions given in the following chapters.



The purpose of the machine is the separation of water and eventual oil particles present in compressed air.



The dried air cannot be used for breathing purposes or for operations leading to direct contact with foodstuff.

This dryer is not suitable for the treatment of dirty air or of air containing solid particles.

3.4 Instructions for the use of pressure equipment according to PED directive 2014/68/EU

To ensure the safe operation of pressure equipments, the user must conform strictly to the above directive and the following:

1. The equipment must only be operated within the temperature and pressure limits stated on the manufacturer's data nameplate.
2. Welding on heat-exchanger is not recommended.
3. The equipment must not be stored in badly ventilated spaces, near a heat source or inflammable substances.
4. Vibration must be eliminated from the equipment to prevent fatigue failure.
5. Automatic condensate drains should be checked for operation every day to prevent a build up of condensate in the pressure equipment.
6. The maximum working pressure stated on the manufacturer's data nameplate must not be exceeded. Prior to use, the user must fit safety / pressure relief devices.
7. All documentation supplied with the equipment (manual, declaration of conformity etc.) must be kept for future reference.
8. Do not apply weights or external loads on the vessel or its connecting piping.



TAMPERING, MODIFICATION AND IMPROPER USE OF THE PRESSURE EQUIPMENT ARE FORBIDDEN. Users of the equipment must comply with all local and national pressure equipment legislation in the country of installation.

4 Installation

4.1 Transport

Check for visible loss or damage, if no visible damage is found place the unit near to the installation point and unpack the contents.

- To move the packaged unit we recommend using a suitable trolley or forklift truck. Hand carrying is not recommended
- Always keep the dryer in the upright vertical position. Damage to components could result if unit is laid on its side or if placed upside down.
- Handle with care. Heavy blows could cause irreparable damage.

4.2 Storage

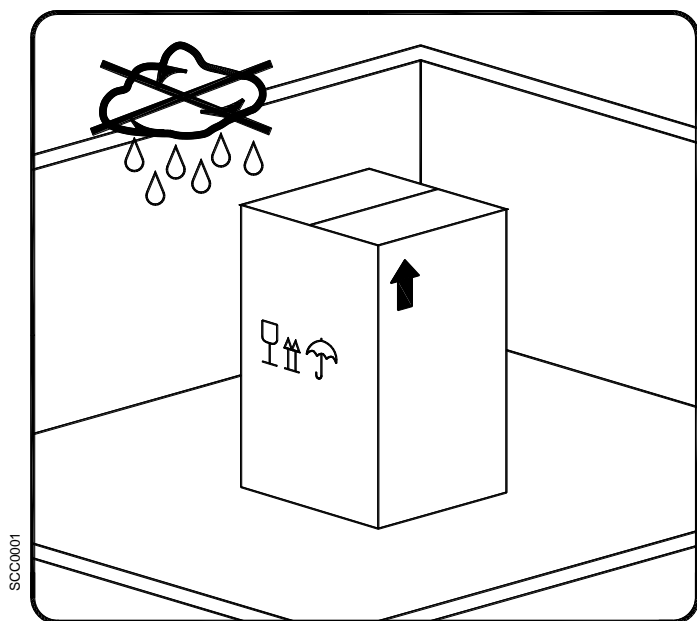

Even when packaged, keep the machine protected from severity of the weather.

Keep the dryer in vertical position, also when stored. Turning it upside down some parts could be irreparably damaged.

If not in use, the dryer can be stored in its packaging in a dust free and protected site at a maximum temperature of 122°F (50°C), and a specific humidity not exceeding 90%. Should the stocking time exceed 12 months, please contact the manufacturer.



The packaging materials are recyclable. Dispose of material in compliance with the rules and regulations in force in the destination country.

4.3 Installation site



Failure to install dryer in the proper ambient conditions will affect the dryer's ability to condense refrigerant gas. This can cause higher loads on the compressor, loss of dryer efficiency and performance, overheated condenser fan motors, electrical component failure and dryer failure due to the following: compressor loss, fan motor failure and electrical component failure. Failures of this type will affect warranty considerations.

Do not install dryer in an environment of corrosive chemicals, explosive gasses, poisonous gasses; steam heat, areas of high ambient conditions or extreme dust and dirt.



In case of fire, use an approved fire extinguisher, water is not an acceptable means in cases of fire.

Minimum installation requirements:

- Select a clean dry area, free from dust, and protected from atmospheric disturbances.
- The supporting area must be smooth, horizontal and able to hold the weight of the dryer.
- Minimum ambient temperature +34°F (+1°C).
- Maximum ambient temperature +122°F (+50°C).
- Ensure a proper cooling air replacement.
- Allow a sufficient clearance on each side of the dryer for proper ventilation and to facilitate maintenance operations.

The dryer does not require attachment to the floor surface.



Do not block, even partially, ventilation grid.
Avoid any possible re-circulation of the exhaust cooling air.
Protect the dryer from air drafts or forced cooling air conditions.

4.4 Installation layout

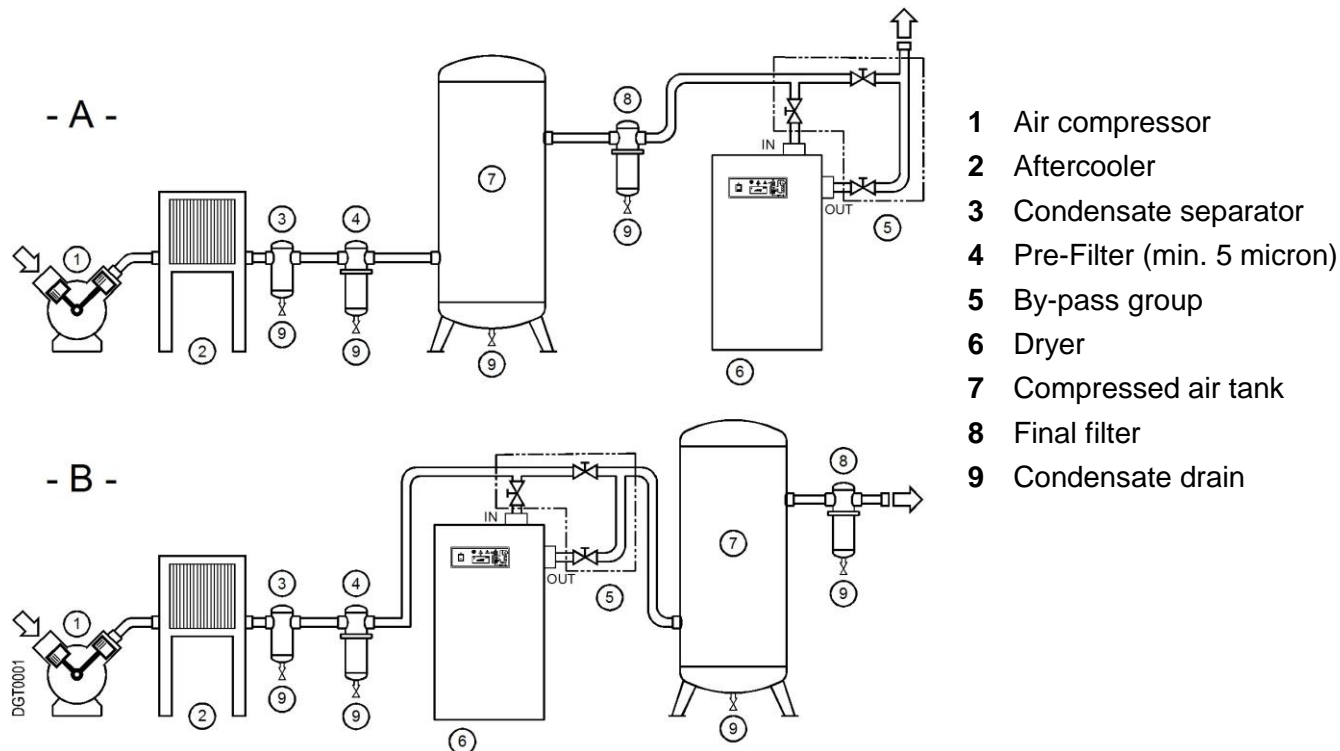

In case of heavily polluted inlet air (ISO 8573.1 class 3.-.3 or worse quality), we recommend the additional installation of a pre-filter (5 micron minimum) to prevent a clogging of the heat exchanger.

Type A installation is suggested when the compressor operates at reduced intermittence and the total consumption equals the compressor flow rate.

Type B installation is suggested when the air consumption can consistently change with peak values highly exceeding the flow rate of the compressors. The capacity of the tank must be sized in order to compensate eventual instantaneous demanding conditions (peak air consumption).

Installation

4.5 Correction factors

Correction factor for operating pressure changes:									
Inlet air pressure	psig	60	80	100	120	140	160	180	203
	barg	4	5.5	7	8	10	11	12	14
Factor (F1)		0.79	0.91	1.00	1.07	1.13	1.18	1.23	1.27

Correction factor for ambient temperature changes (Air-Cooled):									
Ambient temperature	°F	≤ 80	90	95	100	105	110	115	122
	°C	≤ 27	32	35	38	40	43	45	50
Factor (F2)		1.11	1.09	1.06	1.00	0.94	0.87	0.78	0.69

Correction factor for inlet air temperature changes:									
Air temperature	°F	≤ 90	100	110	122	130	140	150	158
	°C	≤ 32	38	43	50	55	60	65	70
Factor (F3)		1.16	1.00	0.82	0.68	0.61	0.52	0.45	0.40

Correction factor for DewPoint changes:									
DewPoint	°F	38	41	45	50				
	°C	3	5	7	10				
Factor (F4)		1.00	1.08	1.20	1.36				

How to find the air flow capacity:

Air flow capacity = Nominal duty x Factor (F1) x Factor (F2) x Factor (F3) x Factor (F4)

Example:
 An **SACT 600** has a nominal duty of 600 scfm (1019 m³/h). What is the maximum allowable flow through the dryer under the following operating conditions:

Inlet air pressure = 120 psig (8 barg)	Factor (F1) = 1.07
Ambient temperature = 115°F (45°C)	Factor (F2) = 0.78
Inlet air temperature = 122°F (50°C)	Factor (F3) = 0.68
Pressure DewPoint = 50°F (10°C)	Factor (F4) = 1.36

Each item of data has a corresponding numerical factor which multiplied by the design air flow is as follows:

Air flow capacity = 600 x 1.07 x 0.78 x 0.68 x 1.36 = 463 scfm (787 m³/h)

463 scfm (787 m³/h) This is the maximum flow rate that the dryer can accept under these operating conditions.

How to select a suitable dryer for a given duty:

Minimum std. air flow rate = $\frac{\text{Design air flow}}{\text{Factor (F1) x Factor (F2) x Factor (F3) x Factor (F4)}}$

Example:
 With the following operating parameters:

Design air flow = 750 scfm (1274 m ³ /h)	Factor (F1) = 1.07
Inlet air pressure = 120 psig (8 barg)	Factor (F2) = 0.78
Ambient temperature = 115°F (45°C)	Factor (F3) = 0.68
Inlet air temperature = 122°F (50°C)	Factor (F4) = 1.36
Pressure DewPoint = 50°F (10°C)	

In order to select the correct dryer model the required flow rate is to be divided by the correction factors relating to above mentioned parameters:

Minimum std. air flow rate = $\frac{750}{1.07 \times 0.78 \times 0.68 \times 1.36} = 972 \text{ scfm (1652 m}^3\text{/h)}$

Therefore the model suitable for the conditions above is **SACT 1000 (1000 scfm [1698 m³/h] - nominal duty).**

4.6 Connection to the compressed air system



Operations to be performed by qualified personnel only.

Never work on system under pressure.



The user is responsible to ensure that the dryer will never be operated with pressure exceeding the maximum pressure rating on the unit data tag.

Over-pressurizing the dryer could be dangerous for both the operator and the unit.

The air temperature and the flow entering the dryer must comply within the limits stated on the data nameplate. The system connecting piping must be kept free from dust, rust, chips and other impurities, and must be consistent with the flow-rate of the dryer. In case of treatment of air at particularly high temperature, the installation of a final refrigerator could result necessary. In order to perform maintenance operations, it is recommended to install a dryer by-pass system.



In case of heavily polluted inlet air (ISO 8573.1 class 3.-.3 or worse quality), we recommend the additional installation of a pre-filter (5 micron minimum) to prevent a clogging of the heat exchanger.

In realising the dryer, particular measures have been taken in order to limit the vibration which could occur during the operation. Therefore we recommend to use connecting pipes able to insulate the dryer from possible vibrations originating from the line (flexible hoses, vibration damping fittings, etc.).

4.7 Connection to the cooling water network (Water-Cooled)



Operations to be performed by qualified personnel only.

Never work on system under pressure.



The user is responsible to ensure that the dryer will never be operated with pressure exceeding the maximum pressure rating on the unit data tag.

Over-pressurizing the dryer could be dangerous for both the operator and the unit.

The temperature and the amount of cooling water must comply with the limits indicated on the technical characteristics chart. The cross section of the connection pipes, preferably flexible, must be free from rust, chips and other impurities. We recommend to use connecting pipes able to insulate the dryer from possible vibrations originating from the line (flexible hoses, vibration damping fittings, etc.).



We recommend the installation of a 500 micron filter to prevent a clogging of the heat exchanger.

Minimum cooling water requirements:

Temperature	59...86°F (15...30°C) (1)	HCO ₃ / SO ₄	>1.0 mg/l or ppm
Pressure	44...145 psig (3...10 barg) (2)	NH ₃	<2 mg/l or ppm
Head pressure	> 44 psig (3 bar) (2) (3)	Cl ⁻	50 mg/l or ppm
Total hardness	6.0...15	Cl ₂	0.5 mg/l or ppm
PH	7.5...9.0	H ₂ S	<0.05 mg/l or ppm
Conductivity	10...500 μS/cm	CO ₂	<5 mg/l or ppm
Residual solid particles	<30 mg/l or ppm	NO ₃	<100 mg/l or ppm
Saturation Index SI	-0.2 < 0 < 0.2	Fe	<0.2 mg/l or ppm
HCO ₃	70...300 mg/l or ppm	Al	<0.2 mg/l or ppm
SO ₄ ²⁻	<70 mg/l or ppm	Mn	<0.1 mg/l or ppm

Note : (1) – Other temperature on request - Check the data shown on the identification plate.

(2) – Other pressure on request - Check the data shown on the identification plate.

(3) – Pressure difference at dryer water connection points at maximum water flow - Other head pressure on request



CAUTION :

PIPING THE DRYER, INLET/OUTLET CONNECTIONS MUST BE SUPPORTED AS SHOWN IN THE DIAGRAM.

FAILING WILL RESULT IN DAMAGE.

4.8 Electrical connections



Qualified personnel should carry out connecting unit to the main power.
Be sure to check the local codes in your area.

Before connecting the unit to the electrical supply, verify the data nameplate for the proper electrical information. Voltage tolerance is +/- 10%. The installer is responsible for supplying and installing the power cable. Be sure to provide the proper fuses or breakers based on the data information located on the nameplate.

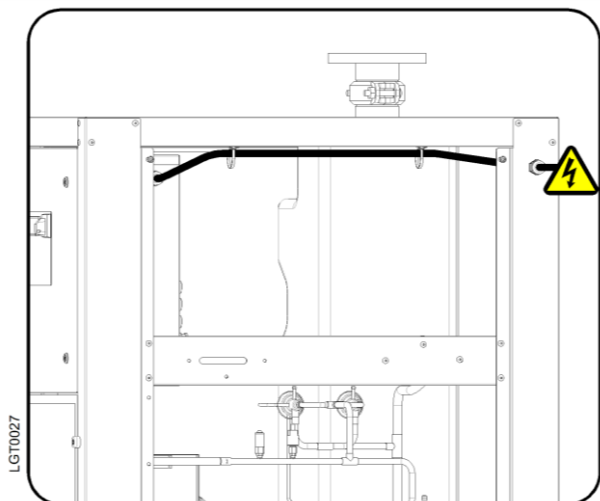

SACT 600 – 1250

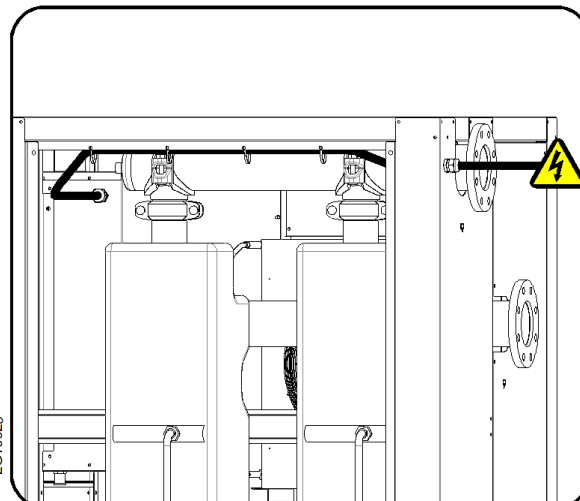

SACT 1500 – 5000

The mains socket must be provided with a mains magneto-thermal differential breaker ($I\Delta n = 0.03A$), adjusted on the basis of the consumption of the dryer (see the nominal values on the data plate of the dryer). The cross section of the power supply cables must comply with the consumption of the dryer, while keeping into account also the ambient temperature, the conditions of the mains installation, the length of the cables, and the requirements enforced by the local Power Provider.

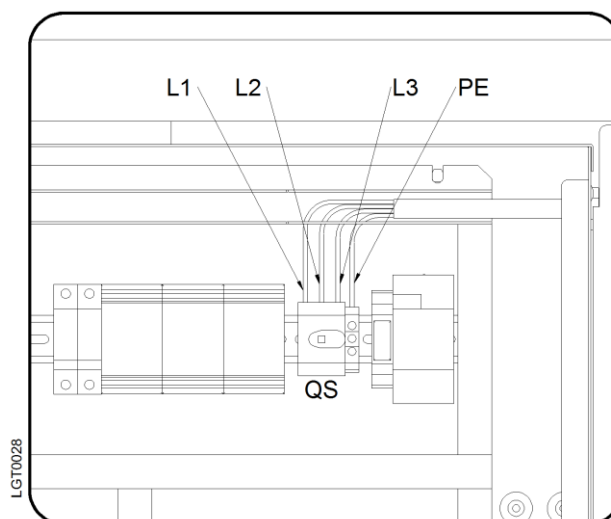

CAUTION:

ATTENTION SHOULD BE PAID ON THE ROTATING DIRECTION OF THE COMPRESSOR !

The rotating direction of the compressor in this machine is checked out by a Reverse Phase Protector (RPP).

When this protection trips, the DMC24 is engaged (the alarm led flashes and the DMC24 display shows **OFF** and **Con**). If the compressor does not run, the rotating direction must be changed by swapping two phases. These changes have to be done only by a qualified electrician.

DO NOT BY PASS RPP PROTECTION: BY OPERATING THE MACHINE IN WRONG ROTATING DIRECTION, THE COMPRESSOR WILL FAIL IMMEDIATELY AND THE WARRANTY WILL BE VOIDED.



Important: ensure that the dryer is earthed.

Do not use any socket adapters at the mains plug.

If the mains plug needs to be replaced, this must only be done by a qualified electrician.

4.9 Condensate drain



The condensate is discharge at the system pressure.
Drain line should be secured.



Never point the condensate drain line towards anybody.

The dryer comes already fitted with an electronic condensate drainer.
Connect and properly fasten the condensate drain to a collecting plant or container.
The drain cannot be connected to pressurized systems.



Don't dispose the condensate in the environment.
The condensate collected in the dryer contains oil particles released in the air by the compressor.
Dispose the condensate in compliance with the local rules.
We recommend to install a water-oil separator where to convey all the condensate drain coming from compressors, dryers, tanks, filters, etc.

5 Start-up

5.1 Preliminary operation



Verify that the operating parameters match with the nominal values stated on the data nameplate of the dryer (voltage, frequency, air pressure, air temperature, ambient temperature, etc.).

This dryer has been thoroughly tested, packaged and inspected prior to shipment. Nevertheless, the unit could be damaged during transportation, check the integrity of the dryer during first start-up and monitor operation during the first hours of operation.



Qualified personnel must perform the first start-up.
When installing and operating this equipment, comply with all National Electrical Code and any applicable federal, state and local codes.



Who is operating the unit is responsible for the proper and safe operation of the dryer.
Never operate equipment with panels removed.



5.2 First start-up



This procedure should be followed on first start-up, after periods of extended shutdown or following maintenance procedures. Qualified personnel must perform the start-up.



Sequence of operations (refer to paragraph 7.1 Control Panel).

- Ensure that all the steps of the “Installation” chapter have been observed.
- Ensure that the connection to the compressed air system is correct and that the piping is suitably fixed and supported.
- Ensure that the condensate drain pipe is properly fastened and connected to a collection system or container.
- Ensure that the by-pass system (if installed) is closed and the dryer is isolated.
- Ensure that the manual valve of the condensate drain circuit is open.
- Remove any packaging and other material which could obstruct the area around the dryer.
- Activate the mains switch.
- Turn on the main switch - pos. 1 on the control panel.
- The electronic instrument DMC24 shows **oFF**.
- **If the alarm led flashes  and display DMC24 shows **oFF** and **Con** the electrical power phases are not correctly connected. Change two of the three phases on the main power supply (see paragraph 4.8)**
- Wait at least two hours before starting the dryer (compressor crankcase heater must heat the oil of the compressor).
- Ensure the cooling water flow and temperature is adequate (Water-Cooled).
- Press key  for at least 2 seconds to start the dryer: if the compressor has been shut down for enough time, it will start up immediately; otherwise the display will show the countdown of the seconds before the compressor starts up again, and the led  flashes (max delay 5 minutes).
- Ensure the consumption matches with the values of the data plate.
- Check the rotation direction of the fan – wait for its first interventions (Air-Cooled).
- Allow the dryer temperature to stabilise at the pre-set value.
- Slowly open the air inlet valve.
- Slowly open the air outlet valve.
- Slowly close the central by-pass valve of the system (if installed).
- Check the piping for air leakage.
- Ensure the drain is regularly cycling - wait for its first interventions.



CAUTION:

ATTENTION SHOULD BE PAID ON THE ROTATING DIRECTION OF THE COMPRESSOR !

The rotating direction of the compressor in this machine is checked out by a Reverse Phase Protector (RPP).

When this protection trips, the DMC24 is engaged (the alarm led flashes  and the DMC24 display shows **oFF** and **Con**). If the compressor does not run, the rotating direction must be changed by swapping two phases. These changes have to be done only by a qualified electrician.

DO NOT BY PASS RPP PROTECTION: BY OPERATING THE MACHINE IN WRONG ROTATING DIRECTION, THE COMPRESSOR WILL FAIL IMMEDIATELY AND THE WARRANTY WILL BE VOIDED.



5.3 Start-up and shut down



For short periods of inactivity, (max 2-3 days) we recommend that power is maintained to the dryer and the control panel. Otherwise, before re-starting the dryer, it is necessary to wait at least 2 hours for the compressor crankcase heater to heat the oil of the compressor.



Start-up (refer to paragraph 7.1 Control Panel)

- Check the condenser for cleanliness (Air-Cooled).
- Ensure the cooling water flow and temperature is adequate (Water-Cooled).
- The electronic instrument DMC24 shows **oFF**.
- Press key  for at least 2 seconds to start the dryer: if the compressor has been shut down for enough time, it will start up immediately; otherwise the display will show the countdown of the seconds before the compressor starts up again, and the led  flashes (max delay 5 minutes).
- Wait few minutes; verify that the DewPoint temperature displayed on electronic instrument is correct and that the condensate is regularly drained.
- Switch on the air compressor.



Shut down (refer to paragraph 7.1 Control Panel)

- Check that the DewPoint temperature indicated on the electronic instrument is within range.
- Shut down the air compressor.
- After few minutes, shut down the dryer keeping the  button on DMC24 pressed for at least 2 seconds. The display shows **oFF**.



Dryer remote control ON-OFF

- See instructions on paragraph 7.15.7



Use dry contacts only (potential free) suitable for low voltage. Assure an adequate isolation of potentially dangerous powered parts.



CAUTION :

AUTO-RESTART / REMOTE ON-OFF.

THE DRYER MAY POWER UP WITHOUT BEING ACTED UPON.

THE USER WILL BE RESPONSIBLE FOR THE INSTALLATION OF PROPER PROTECTIONS FOR POSSIBLE SUDDEN POWER RESTORATION TO THE DRYER.

NOTE : A DewPoint within 32°F (0°C) and +50°F (+10°C) displayed on electronic instrument is correct according to the possible working conditions (flow-rate, temperature of the incoming air, ambient temperature, etc.).

During the operation, the refrigerant compressor will run continuously. The dryer must remain on during the full usage period of the compressed air, even if the air compressor works intermittently.



The number of starts must be no more than 6 per hour.

The dryer must stop running for at least 5 minutes before being started up again.

Frequent starts may cause irreparable damage.

The user is responsible for compliance with these rules.

The DMC24 is fitted with internal protections to prevent the dryer from starting up too frequently.

6 Technical data

6.1 Technical data SACT 600 – 5000 3/460/60

MODEL	SACT	600-UR	800-UR	1000-UR	1250-UR	1500-UR	1750-UR	2000-UR	2500-UR	3000-UR	3750-UR	4000-UR	5000-UR
Air flow rate at nominal condition (1)		600 [scfm] 1019 [m ³ /h] 16980 [l/min]	800 1358 22640	1000 1698 28300	1250 2123 35375	1500 2547 42450	1750 2972 49525	2000 3396 56600	2500 4245 70750	3000 5094 84900	3750 6368 106125	4000 6792 113200	5000 8490 141500
Pressure DewPoint at nominal condition (1)		38 (3)											
Nominal ambient temperature		100 (38)											
Min. Max ambient temperature		34...122 (1...50)											
Nominal inlet air temperature		100 (38) max.158 (70)											
Nominal inlet air pressure		100 (7)											
Max. inlet air pressure		203 (14)											
Air pressure drop - Ap		4" # 150											
Inlet - Outlet connections		3" # 150											

		R407C											
Refrigerant type		R407C											
Refrigerant quantity (2)		102 (2.90)	113 (3.20)	152 (4.30)	173 (4.90)	229 (6.50)	236 (6.70)	247 (7.00)	360 (10.20)	405 (11.50)	510 (14.50)	530 (15.00)	740 (21.00)
Cooling air fan flow		3500 (5900)	4700 (7900)	4800 (8200)	7100 (12000)	9400 (16000)	9400 (16000)	9700 (16500)	14100 (24000)	14400 (24500)	18800 (32000)	18800 (32000)	19500 (33000)
Heat Rejection		28100 (8.2)	35800 (10.5)	52200 (15.3)	66100 (19.4)	88000 (25.8)	90100 (26.4)	97100 (28.5)	131400 (38.5)	174700 (51.2)	225200 (66.0)	226900 (66.5)	353200 (103.5)
Standard Power Supply (2)		3/460/60											
Nominal electric consumption		2.65 [kW]	3.25 [kW]	4.60 [kW]	5.60 [kW]	6.40 [kW]	7.50 [kW]	8.60 [kW]	9.80 [kW]	12.20 [kW]	14.70 [kW]	15.70 [kW]	23.50 [kW]
Full Load Amperage FLA		4.1 [A]	5.0 [A]	6.4 [A]	7.5 [A]	9.0 [A]	10.0 [A]	11.8 [A]	14.3 [A]	17.9 [A]	22.6 [A]	23.9 [A]	33.9 [A]
Max. noise level at 1 m		6.1 [dBA]	7.1 [dBA]	10.5 [dBA]	11.5 [dBA]	14.7 [dBA]	16.5 [dBA]	18.4 [dBA]	23.0 [dBA]	31.0 [dBA]	38.0 [dBA]	40.0 [dBA]	49.0 [dBA]
Weight		529 (240)	534 (242)	608 (276)	686 (311)	1021 (463)	1186 (538)	1190 (540)	1349 (612)	1830 (830)	2070 (940)	2330 (1055)	2650 (1200)

		R407C											
Refrigerant type		R407C											
Refrigerant quantity (2)		92 (2.60)	102 (2.90)	137 (3.90)	155 (4.40)	208 (5.90)	212 (6.00)	222 (6.30)	324 (9.20)	367 (10.40)	462 (13.10)	476 (13.50)	670 (19.00)
Max. cooling water inlet temp (3)		86 (30)											
Min. Max. cooling water inlet pressure		45...145 (3...10)											
Cooling water flow at 15°C		1.01 (0.23)	1.10 (0.25)	1.72 (0.39)	1.94 (0.44)	2.51 (0.57)	2.55 (0.58)	2.99 (0.68)	3.70 (0.84)	4.84 (1.10)	6.34 (1.44)	6.78 (1.54)	9.82 (2.23)
Cooling water flow at 30°C		3.57 (0.81)	3.70 (0.84)	6.43 (1.46)	6.47 (1.47)	8.01 (1.82)	8.41 (1.91)	9.82 (2.23)	12.77 (2.90)	16.25 (3.69)	22.67 (5.15)	23.03 (5.23)	34.78 (7.90)
Heat Rejection		28100 (8.2)	35800 (10.5)	52200 (15.3)	66100 (19.4)	88000 (25.8)	90100 (26.4)	97100 (28.5)	131400 (38.5)	174700 (51.2)	225200 (66.0)	226900 (66.5)	353200 (103.5)
Control of cooling water flow		Automatic by valve											
Cooling water connection		1"											
Standard Power Supply (2)		3/4"											
Nominal electric consumption		2.27 [kW]	2.92 [kW]	3.75 [kW]	4.90 [kW]	5.00 [kW]	5.90 [kW]	7.20 [kW]	8.40 [kW]	9.80 [kW]	12.30 [kW]	12.50 [kW]	20.00 [kW]
Full Load Amperage FLA		3.4 [A]	4.3 [A]	5.1 [A]	6.4 [A]	7.5 [A]	7.6 [A]	9.2 [A]	11.7 [A]	14.3 [A]	18.6 [A]	18.9 [A]	28.7 [A]
Max. noise level at 1 m		5.7 [dBA]	6.0 [dBA]	8.5 [dBA]	9.5 [dBA]	12.5 [dBA]	12.5 [dBA]	12.9 [dBA]	19.0 [dBA]	25.0 [dBA]	32.0 [dBA]	32.0 [dBA]	41.0 [dBA]
Weight		496 (225)	500 (227)	567 (257)	635 (288)	950 (431)	1098 (498)	1102 (500)	1239 (562)	1698 (770)	2072 (940)	2326 (1055)	2646 (1200)

(1) The nominal condition refers to an ambient temperature of 100°F (38°C) with inlet air at 100 psig (7 barg) and 100°F (38°C).
 (2) Check the data shown on the identification plate.
 (3) Other temperature on request.

6.2 Technical data SACT 600 – 5000 3/380/60

MODEL	SACT	600-JF	800-JF	1000-JF	1250-JF	1500-JF	1750-JF	2000-JF	2500-JF	3000-JF	3750-JF	4000-JF	5000-JF															
Air flow rate at nominal condition (1)	[scfm] [m ³ /h]	600 1019	800 1358	1000 1698	1250 2123	1500 2547	1750 2972	2000 3396	2500 4245	3000 5094	3750 6368	4000 6792	5000 8490															
Pressure DewPoint at nominal condition (1)	[°F (°C)]	38 (3)																										
Nominal ambient temperature	[°F (°C)]	100 (38)																										
Min...Max ambient temperature	[°F (°C)]	34...122 (1...50)																										
Nominal inlet air temperature	[°F (°C)]	100 (38) max.158 (70)																										
Nominal inlet air pressure	[psig (barg)]	100 (7)																										
Max. inlet air pressure	[psig (barg)]	203 (14)																										
Air pressure drop - Δp	[psi (bar)]	2.2 (0.15)			2.9 (0.20)			2.8 (0.19)			2.6 (0.18)			3.6 (0.25)			2.8 (0.19)			3.8 (0.26)			2.8 (0.19)			4.1 (0.28)		
Inlet - Outlet connections	[FLANSI]	3" # 150			3" # 150			4" # 150			4" # 150			6" # 150			6" # 150			8" # 150			8" # 150					

Air-Cooled													
R407C													
Refrigerant type		R407C											
Refrigerant quantity (2)	[oz (kg)]	102 (2.90)	113 (3.20)	152 (4.30)	173 (4.90)	229 (6.50)	236 (6.70)	247 (7.00)	360 (10.20)	405 (11.50)	510 (14.50)	530 (15.00)	740 (21.00)
Cooling air fan flow	[cfm (m ³ /h)]	3500 (5900)	4700 (7900)	4800 (8200)	7100 (12000)	9400 (16000)	9400 (16000)	9700 (16500)	14100 (24000)	14400 (24500)	18800 (32000)	18800 (32000)	19500 (33000)
Heat Rejection	[btu/hr (kW)]	28100 (8.2)	35800 (10.5)	52200 (15.3)	66100 (19.4)	88000 (25.8)	90100 (26.4)	97100 (28.5)	131400 (38.5)	174700 (51.2)	225200 (66.0)	226900 (66.5)	353200 (103.5)
Standard Power Supply (2)	[PhiV/Hz]	3/380/60											
Nominal electric consumption	[kW]	2.65	3.25	4.60	5.60	6.40	7.50	8.60	9.80	12.20	14.70	15.70	23.50
Full Load Amperage FLA	[A]	5.0	6.1	7.7	9.1	10.9	12.1	14.3	17.3	21.7	27.4	28.9	41.0
Max. noise level at 1 m	[dba]	7.4	8.6	12.7	13.9	17.8	20.0	22.3	27.8	37.5	46.0	48.4	59.3
Weight	[lb (kg)]	529 (240)	534 (242)	608 (276)	686 (311)	1021 (463)	1186 (538)	1190 (540)	1349 (612)	1830 (830)	2070 (940)	2330 (1055)	2650 (1200)

Water-Cooled													
R407C													
Refrigerant type		R407C											
Refrigerant quantity (2)	[oz (kg)]	92 (2.60)	102 (2.90)	137 (3.90)	155 (4.40)	208 (5.90)	212 (6.00)	222 (6.30)	324 (9.20)	367 (10.40)	462 (13.10)	476 (13.50)	670 (19.00)
Max. cooling water inlet temp (3)	[°F (°C)]	86 (30)											
Min. Max. cooling water inlet pressure	[psig (barg)]	45...145 (3...10)											
Cooling water flow at 15°C	[US gpm (m ³ /h)]	1.01 (0.23)	1.10 (0.25)	1.72 (0.39)	1.94 (0.44)	2.51 (0.57)	2.55 (0.58)	2.99 (0.68)	3.70 (0.84)	4.84 (1.10)	6.34 (1.44)	6.78 (1.54)	9.82 (2.23)
Cooling water flow at 30°C	[US gpm (m ³ /h)]	3.57 (0.81)	3.70 (0.84)	6.43 (1.46)	6.47 (1.47)	8.01 (1.82)	8.41 (1.91)	9.82 (2.23)	12.77 (2.90)	16.25 (3.69)	22.67 (5.15)	23.03 (5.23)	34.78 (7.90)
Heat Rejection	[btu/hr (kW)]	28100 (8.2)	35800 (10.5)	52200 (15.3)	66100 (19.4)	88000 (25.8)	90100 (26.4)	97100 (28.5)	131400 (38.5)	174700 (51.2)	225200 (66.0)	226900 (66.5)	353200 (103.5)
Control of cooling water flow		Automatic by valve											
Cooling water connection	[NPT-F]	3/4"			1"			1 1/2"			2"		
Standard Power Supply (2)	[PhiV/Hz]	3/380/60											
Nominal electric consumption	[kW]	2.27	2.92	3.75	4.90	5.00	5.90	7.20	8.40	11.90	14.90	15.10	24.20
Full Load Amperage FLA	[A]	4.1	5.2	6.2	7.7	9.1	9.2	11.1	14.2	17.3	22.5	22.9	34.7
Max. noise level at 1 m	[dba]	6.9	7.3	10.3	11.5	15.1	15.1	15.6	23.0	30.3	38.7	38.7	49.6
Weight	[lb (kg)]	496 (225)	500 (227)	567 (257)	635 (288)	950 (431)	1098 (498)	1102 (500)	1239 (562)	1698 (770)	2072 (940)	2326 (1055)	2646 (1200)

(1) The nominal condition refers to an ambient temperature of 100°F (38°C) with inlet air at 100 psig (7 barg) and 100°F (38°C).
 (2) Check the data shown on the identification plate.
 (3) Other temperature on request.

7 Technical description

7.1 Control panel

The control panel illustrated below is the only dryer-operator interface.

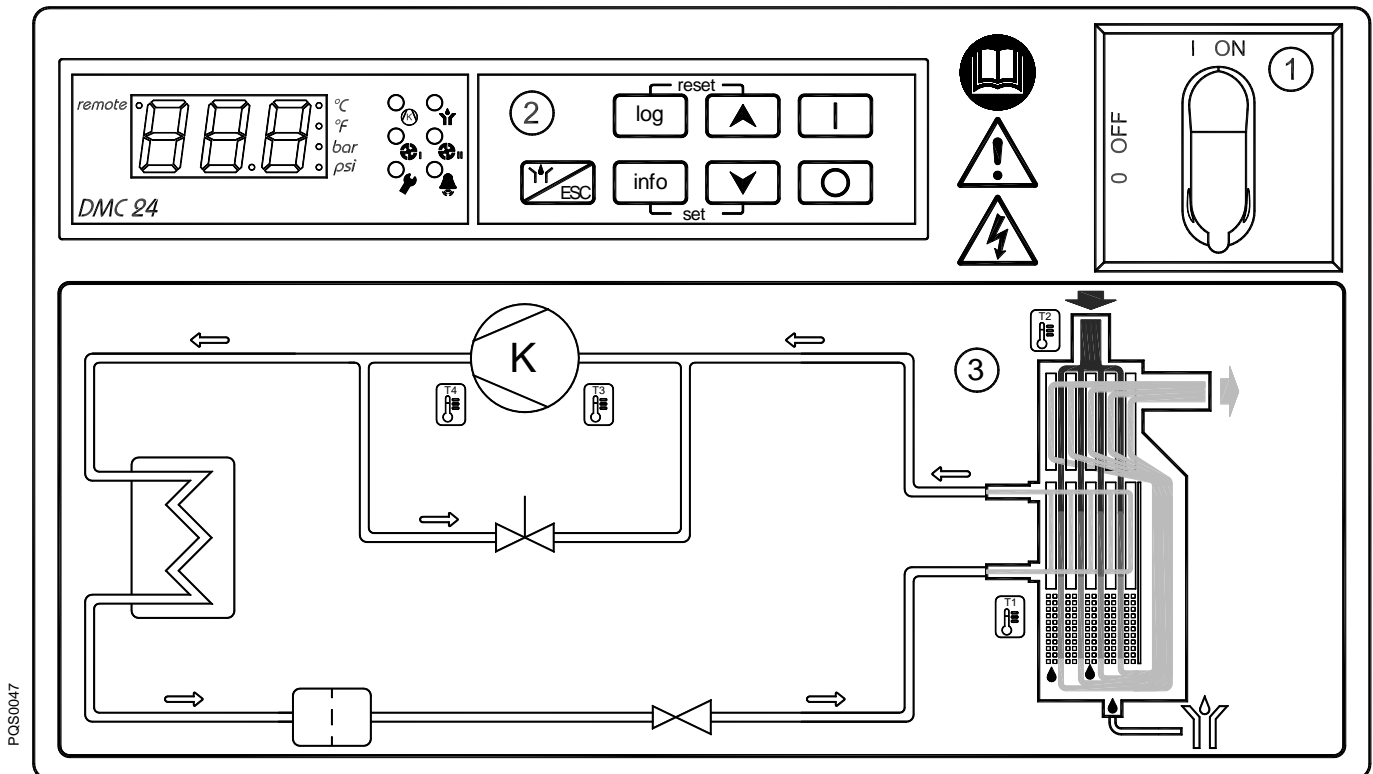

- 1 Main switch
- 2 Electronic instrument DMC24
- 3 Air and refrigerant flow diagram

7.2 Operation

Operating principle - The dryer models described in this manual operate all on the same principle. The hot moisture laden air enters an air to air heat exchanger. The air then goes through the evaporator, also known as the air to refrigerant heat exchanger. The temperature of the air is reduced to approximately 36°F (2°C), causing water vapor to condense to liquid. The liquid is continuously coalesced and collected in the separator for removal by the condensate drain. The cool moisture free air then passes back through the air to air heat exchanger to be reheated to within 8 degrees of the incoming air temperature as it exits the dryer.

Refrigerant circuit - Refrigerant gas is cycled through the compressor and exits at high pressure to a condenser where heat is removed causing the refrigerant to condense to a high-pressure liquid state. The liquid is forced through a capillary tube where the resulting pressure drop allows the refrigerant to boil off at a predetermined temperature. Low-pressure liquid refrigerant enters the heat exchanger where heat from the incoming air is transferred causing the refrigerant to boil; the resulting phase change produces a low pressure, low temperature gas. The low-pressure gas is returned to the compressor, where it is re-compressed and begins the cycle again. During those periods when the compressed air load is reduced the excess refrigerant is by-passed automatically back to the compressor via the hot gas by-pass valve circuit.

7.3 Flow diagram (Air-Cooled)

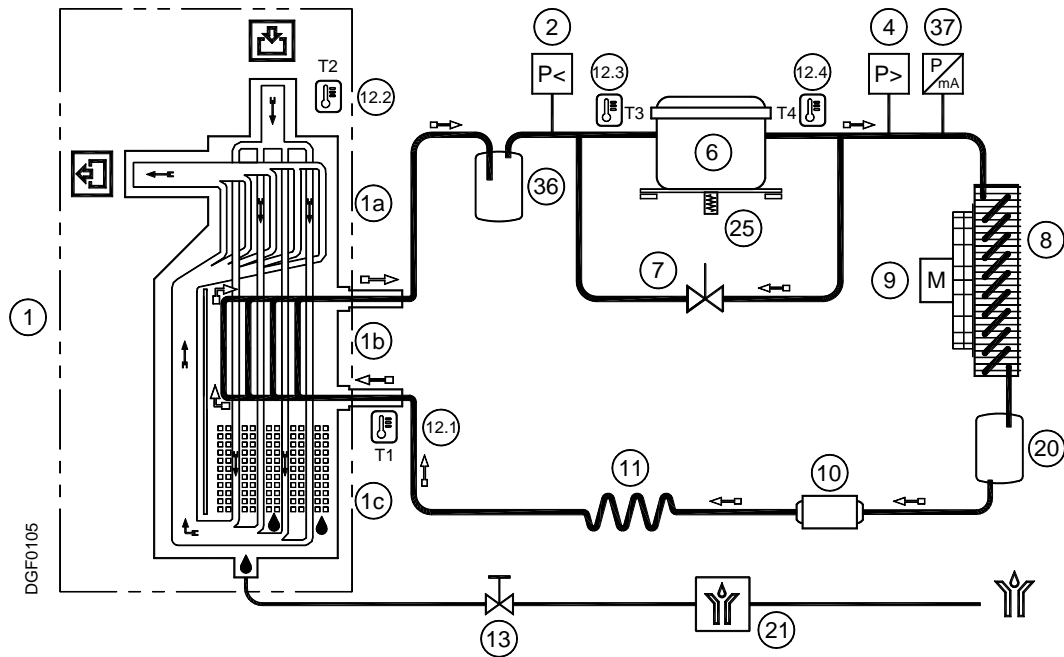

7.4 Flow diagram (Water-Cooled)

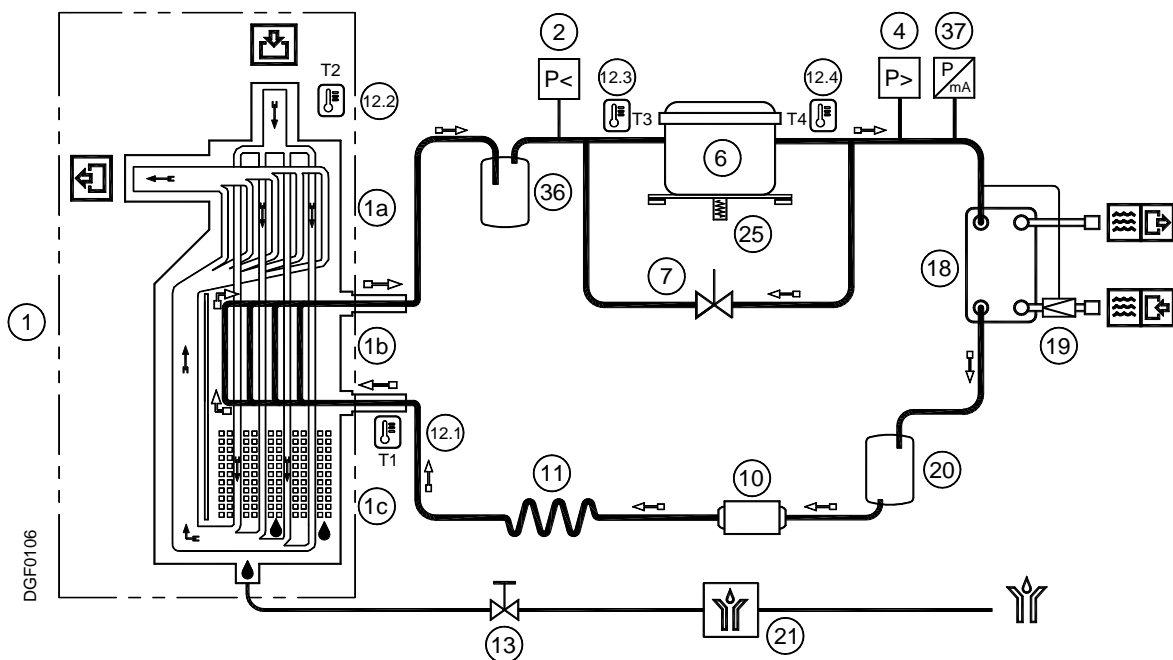

- | | |
|--|---|
| <p>1 Alu-Dry module</p> <p>1a Air-to-air heat exchanger</p> <p>1b Air-to-refrigerant heat exchanger</p> <p>1c Condensate separator</p> <p>2 Refrigerant pressure switch LPS</p> <p>4 Refrigerant pressure switch HPS</p> <p>6 Compressor</p> <p>7 Hot gas by-pass valve</p> <p>8 Condenser (Air-Cooled)</p> <p>9 Condenser fan (Air-Cooled)</p> <p>10 Filter dryer</p> <p>11 Capillary tube</p> <p>12.1 T1 Temperature probe – DewPoint</p> <p>➡ Compressed air flow direction</p> | <p>12.2 T2 Temperature probe – Air IN</p> <p>12.3 T3 Temperature probe – Compressor suction</p> <p>12.4 T4 Temperature probe – Compressor discharge</p> <p>13 Condensate drain service valve</p> <p>18 Condenser (Water-Cooled)</p> <p>19 Condenser water regulating valve (Water-Cooled)</p> <p>20 Refrigerant accumulator
(SACT 3000-5000 A.Cooled & SACT 600-5000 W.Cool.)</p> <p>21 Electronic drainer</p> <p>25 Compressor crankcase heater</p> <p>36 Liquid separator</p> <p>37 Refrigerant pressure transducer BHP</p> <p>➡ Refrigerant gas flow direction</p> |
|--|---|

7.5 Refrigerating compressor

The refrigerating compressor is the pump in the system, gas coming from the evaporator (low pressure side) is compressed up to the condensation pressure (high pressure side). The compressors utilized are manufactured by leading manufacturers and are designed for applications where high compression ratios and wide temperature changes are present.

The hermetically sealed construction is perfectly gas tight, ensuring high-energy efficiency and long, useful life. Dumping springs support the pumping unit in order to reduce the acoustic emission and the vibration diffusion. The aspirated refrigerant gas, flowing through the coils before reaching the compression cylinders cools the electric motor. The thermal protection protects the compressor from over heating and over currents. The protection is automatically restored as soon as the nominal temperature conditions are reached.

7.6 Condenser (Air-Cooled)

The condenser is the component in which the gas coming from the compressor is cooled down and condensed becoming a liquid. Mechanically, a serpentine copper tubing circuit (with the gas flowing inside) is encapsulated in an aluminum fin package.

The cooling operation occurs via a high efficiency fan, creating airflow within the dryer, moving air through the fin package. It's mandatory that the ambient air temperature does not exceed the nominal values. It is also important to keep the condenser unit free from dust and other impurities.

7.7 Condenser (Water-Cooled)

The condenser is the component in which the gas coming from the compressor is cooled down and condensed becoming a liquid. Basically it is a water/refrigerating gas exchanger where the cooling water lowers the temperature of the refrigerating gas.

The temperature of the inlet water must not exceed the nominal values. It must also guarantee an adequate flow and that the water entering the exchanger is free from dust and other impurities.

7.8 Condenser water regulating valve (Water-Cooled)

The condenser water regulating valve is used to keep the condensing pressure/temperature constant when the Water-Cooled is being used. Thanks to the capillary tube, the valve detects the pressure in the condenser and consequently adjusts the water flow. When the dryer stops the valve automatically closes the cooling water flow.



The condenser water regulating valve is an operating control device.

The closure of the water circuit from the pressure condenser water regulating valve cannot be used as a safety closure during service operations on the system.



ADJUSTMENT

The condenser water regulating valve is adjusted during the testing phase to a pre-set value that covers 90% of the applications. However, sometimes the extreme operating conditions of the dryer may require a more accurate calibration.

During start-up, a qualified technician should check the condensing pressure/temperature and if necessary adjust the valve by using the screws on the valve itself.

To increase the condensing temperature, turn the adjusting screws counter-clockwise; to lower it turn the screws clock-wise.

Water valve setting : R407C pressure 232 psig (± 7.3 psi) [16 barg (± 0.5 bar)]

7.9 Filter dryer

Traces of humidity and slag can accumulate inside the refrigerant circuit. Long periods of use can also produce sludge. This can limit the lubrication efficiency of the compressor and clog the expansion valve or capillary tube. The function of the filter drier, located before the capillary tubing, is to eliminate any impurities from circulating through the system.

7.10 Capillary tube

It consists of a piece of reduced cross section copper tubing located between the condenser and the evaporator, acting as a metering device to reduce the pressure of the refrigerant. Reduction of pressure is a design function to achieve optimum temperature reached within the evaporator: the smaller the capillary tube outlet pressure, the lower the evaporation temperature.

The length and interior diameter of the capillary tubing is accurately sized to establish the performance of the dryer; no maintenance or adjustment is necessary.

7.11 Alu-Dry module

The heat exchanger module houses the air-to-air, the air-to-refrigerant heat exchangers and the demister type condensate separator. The counter flow of compressed air in the air-to-air heat exchanger ensures maximum heat transfer. The generous cross section of flow channel within the heat exchanger module leads to low velocities and reduced power requirements. The generous dimensions of the air-to-refrigerant heat exchanger plus the counter flow gas flow allows full and complete evaporation of the refrigerant (preventing liquid return to the compressor). The high efficiency condensate separator is located within the heat exchanger module. No maintenance is required and the coalescing effect results in a high degree of moisture separation.

7.12 Hot gas by-pass valve

This valve injects part of the hot gas (taken from the discharge side of the compressor) in the pipe between the evaporator and the suction side of the compressor, keeping the evaporation temperature/pressure constant at approx. +36°F (+2°C). This injection prevents the formation of ice inside the dryer evaporator at every load condition.



ADJUSTMENT

The hot gas by-pass valve is adjusted during the manufacturing testing phase. As a rule no adjustment is required; anyway if it is necessary the operation must be carried out by an experienced refrigerating engineer.

WARNING

the use of ¼" Schrader service valves must be justified by a real malfunction of the refrigerating system. Each time a pressure gauge is connected, a part of refrigerant is exhausted. Without compressed air flow through the dryer, rotate the adjusting screw (position A on the drawing) until the following value is reached:

Hot gas setting : R407C pressure 65.3 psig (+1.45 / -0 psi) [4.5 barg (+0.1 / -0 bar)]

SACT 600 – 1250

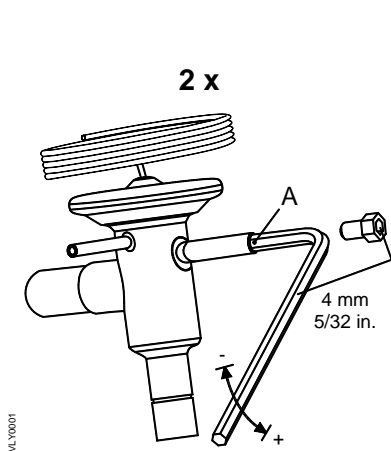

SACT 1500 – 3000

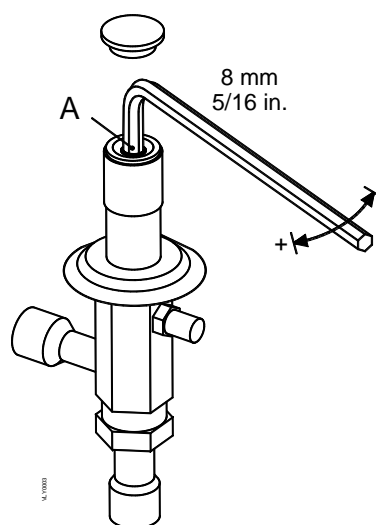

SACT 3750 – 5000

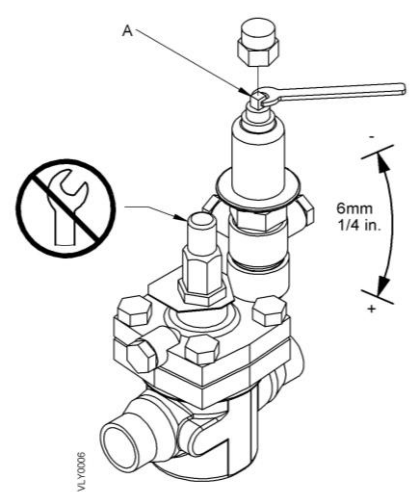

7.13 Refrigerant pressure switches LPS – HPS

As operation safety and protection of the dryer a series of pressure switches are installed in the gas circuit.

LPS : Low-pressure protection device on the suction side of the compressor, trips if the pressure drops below the pre-set value. The values are automatically reset when the nominal conditions are restored.

Calibrated pressure : R 407 C Stop 24.7 psig (1.7 barg) - Restart 53.7 psig (3.7 barg)

HPS : This high-pressure controller device, located on the discharge side on the compressor, is activated when the pressure exceeds the pre-set value. It features a manual-resetting button mounted on the controller itself.

Calibrated pressure : R 407 C Stop 435 psig (30 barg) - Manual reset P<334 psi (P<23 bar)

7.14 Compressor crankcase heater

At low temperatures oil can more easily be mixed with the refrigerant gas. So, when the compressor starts, oil can be drawn into the refrigeration circuit and liquid hammering could occur.

To prevent this, an electrical resistance heater is installed in the suction side of the compressor. When the system is powered and the compressor is not running, this heater keeps the oil at the correct temperature.

This heater is controlled by a thermo switch which prevents overheating the oil.

NOTE : The heater must be powered at least a couple of hours before the start up of the refrigeration compressor.

7.15 Electronic instrument DMC24

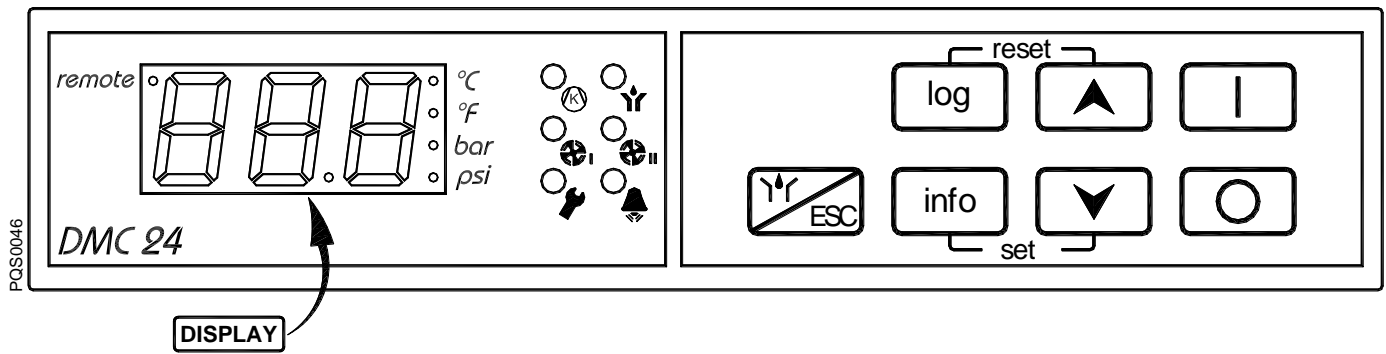

- LED**
- (K) Compressor ON – green
 - Y Drain ON – green
 - ⊕_I Fan 1 ON – green
 - ⊕_{II} Fan 2 ON – green
 - W Service warning – orange
 - Alarm – red
 - remote ○ Remote control enabled
 - °C Temperature in °C
 - °F Temperature in °F
 - bar Pressure in barg
 - psi Pressure in psig

- BUTTON**
- I ON
 - OFF
 - ▲ Increase
 - ▼ Decrease
 - log Log
 - info Info menu
 - Y ESC Drain test / ESC
 - info ▼ set Setup menu on
 - log ▲ reset Reset alarms and/or service

The DMC24 controls all the operations, alarms and dryer operation set-up. The display and the leds show all the operating conditions.

Led ○ (K) shows that the compressor is ON.



The operation of the fans is indicated by the leds ○ ⊕_I and ○ ⊕_{II}.

During normal operation the display shows the DewPoint temperature.

7.15.1 How to switch on the dryer

When the unit is powered the display shows **oFF**.

The condensate drain test is always active through button .

Press  for at least 2 seconds to start the dryer: if the compressor has been shut down for enough time, it will start up immediately; otherwise the display will show the countdown of the seconds before the compressor starts up again, and the led  flashes (max delay 5 minutes).





7.15.2 How to switch off the dryer

From any menu press  for at least 2 seconds. The display shows **oFF**.

7.15.3 How to display the operating parameters – INFO Menu

The info menu shows the dynamic operating parameters of the dryer.

With the dryer ON and not in other menus, press  for at least 1 second to enter the info menu.

Access to the info menu is confirmed by message **t I** on the display (first parameter of the menu). Use the arrows  and  to move to the following/previous. Press  to show the value of the selected parameter. Press  again to return to the list of displayable parameters.

Press  to exit info menu (if no button is pressed after 2 minutes the menu is exited automatically).



Info	Description
t I	T1 - Temperature probe T1 – DewPoint
t2	T2 – Temperature probe T2 – Air IN
t3	T3 – Temperature probe T3 – compressor suction
t4	T4 – Temperature probe T4 – compressor discharge
HP	HP – condensing pressure HP
HrS	HrS – total hours of operation
SrV	SrV – hours until next service

Note : The temperatures are displayed in °C or °F (led  is lighted).

Pressure is displayed in barg or psig (led  is lighted).



The total hours of operation and the hours until the next service are shown in the field 0...999 hours and in thousands of hours from 01.0 hours on (example : if the display shows number 35 it means 35 hours; if the display shows number 3.5 it means 3500 hours).

7.15.4 How a service warning is displayed

A service warning is an unusual event that must recall the attention of operators/maintenance technicians. Generally it does not stop the dryer (except for a high DewPoint parameter that can be set to stop the dryer). When the service warning is active the led  flashes. If the service warning is memorized (it tripped but then it switched off by itself) led  is lighted.

In both cases the display shows the DewPoint temperature and the service warnings that are active or not active but that have not yet been reset.

Service warnings are not automatically reset (except for *drn* that can be set in auto-reset).

To **RESET** the service warning press the buttons   simultaneously for 3 seconds. Only the memorized service warning will be reset, whereas the service warning are still engaged will remain displayed and the led  flashes.



NOTE: the operator/maintenance technician must inspect the dryer and verify/solve the problem that generated the service warning.

Service Warning	Description
<i>PF 1</i>	PF1 - Probe 1 Failure : failure temperature probe 1
<i>PF 2</i>	PF2 - Probe 2 Failure : failure temperature probe 2
<i>PF 3</i>	PF3 - Probe 3 Failure : failure temperature probe 3
<i>HdP</i>	HdP - High DewPoint: DewPoint too high, higher than the HdA value set.
<i>LdP</i>	LdP - Low DewPoint : DewPoint too low Set T1 < -1°C (30°F) delay 5 minutes / Reset T1 > 0°C (32°F)
<i>drn</i>	drn - Drainer : condensate drainer failure (opening of contact DRN – if electronic level drainer is installed – see electric diagram)
<i>SrV</i>	SrV - Service : maintenance service time expired SrV
<i>dt</i>	dt - Discharge Temperature : compressor discharge temperature (probe T4) beyond normal values, but within safety limits Set T4 > 90°C (194°F) delay 3 minutes / Reset T4 < 85°C (185°F)
<i>HCP</i>	HCP - High Condensing Pressure : condensing pressure (transducer BHP) beyond normal values, but within safety limits Set HP > 28barg (406psig) delay 3 minutes / Reset HP < 25barg (363psig)

NOTE: with dryer ON, but without compressed air pressure, the drainer failure notice *drn* may appear.



7.15.5 How an alarm is displayed

The alarm is an unusual event that always causes the dryer to switch OFF for the safety of the machine and the operators.

When the alarm is active the led  flashes. If the alarm is memorized (it tripped but then it switched off by itself) led  is lighted (dryer stay OFF in any case).

When the led  flashes the message **OFF** and the active alarm/s appear in sequence on the display.

When the led  is lighted, the message **OFF** and the alarm/s that tripped and require to be reset appear in sequence on the display.

The alarms are not automatically reset. To **RESET** the alarm the led  must be lighted and the buttons   must be pressed simultaneously for at least 3 seconds.





The dryer does not start up automatically after the alarms have been reset.

NOTE: the operator/maintenance technician must inspect the dryer and verify/solve the problem that generated the service warning.

Alarm	Description
HP	HP - High Pressure : the refrigerant high pressure safety pressure switch HPS tripped (note : the pressure switch has a reset button)
LP	LP - Low Pressure : the refrigerant low pressure safety pressure switch LPS tripped
CO_n	CO _n - Compressor : the compressor's protections and/or the reverse phase protector RPP tripped
FA_n	FA _n - Fan : the fan protections tripped
Hdt	Hdt - High Discharge Temperature : compressor discharge temperature beyond the safety limit Set T4> 100°C (212°F) delay 1 minute / Reset T4< 90°C (194°F)
ICE	ICE - ICE / freezing : temperature inside the exchanger (probe T1) is too low and causes the condensate to freeze. Set T1< -3°C (27°F) delay 1 minute / Reset T1> 0°C (32°F)
LCP	LCP - Low Condensing Pressure : condensing pressure too low
PF4	PF4 - Probe 4 Failure : failure probe 4
PFP	PFP - Probe Pressure Failure : failure condensing pressure trasducer BHP

7.15.6 How to show the alarm memory – LOG Menu

The log menu is the list of the last 10 alarms (only alarms, not service warning). They appear in chronological order (LIFO logic).

With dryer ON or OFF and not in other menus, press  for at least 1 second to enter the log menu. Access to the log menu is confirmed by message **L O I** (L01) on the display (first parameter of menu). Use the arrows  and  to move to following/previous (L01 ... L10). Press  to show the selected log value. Alternatively the parameter that generated the alarm and the hours of operation of the machine when the alarm tripped are shown. Press  again to return to the log list.

Press  to exit log menu (if no button is pressed after 2 minutes the menu is exited automatically).

NOTE: an empty position in the log list is displayed by the message **NOI**.

7.15.7 How to control dryer with remote control

The DMC24 can be easily controlled using 2 digital inputs connected to terminals 1, 2 and 3 (see electric diagram).

Close the contact between the terminals 2 and 3 to enable the remote control, the led *remote*  turns on and it is no longer possible to switch the dryer ON or OFF from local panel (the condensate drain test is possible and access to info and log menus).

Having contact between terminals 2 and 3 closed, close the second contact between the terminals 1 and 2 to switch ON the dryer. Open the contact between the terminals 1 and 2 to switch OFF the dryer.



Use dry contacts only (potential free) suitable for low voltage. Assure an adequate isolation of potentially dangerous powered parts.



**CAUTION:
AUTO-RESTART / REMOTE ON-OFF
THE DRYER MAY POWER UP WITHOUT BEING ACTED UPON.
THE USER WILL BE RESPONSIBLE FOR THE INSTALLATION OF PROPER PROTECTIONS
FOR POSSIBLE SUDDEN POWER RESTORATION TO THE DRYER.**

7.15.8 Operation of the failure / alarm dry contact (potential free)

The DMC24 is equipped with a dry contact (potential free) to display failure and/or alarm conditions.

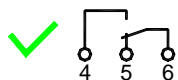

Dryer powered and no service warning or alarm (active and not yet reset) displayed.

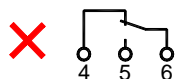

Dryer not powered or service warning or alarm (active and not yet reset) displayed.

7.15.9 Connection to serial line

The DMC24 can be connected to a supervision serial line, remote control or download of log file (memory) of alarms.

Contact your distributor or service centre for more information.



Technical description



7.15.10 How to change operating parameters – SETUP Menu





The setup menu can be used to change the dryer's operating parameters.



Only qualified personnel must be allowed to access to the setup menu. The manufacturer is not responsible for malfunctioning or failure due to modification to the operating parameters.

With dryer ON or OFF and not in other menus, simultaneously press buttons   for at least 5 seconds to enter the setup menu.

Access to the info menu is confirmed by message **ton** on the display (first parameter of menu). Use arrows  and  to move to following/previous one.

Keep  pressed to display the value of the selected parameter and use arrows  and  to change the value. Release the button  to confirm the value and skip to following parameter.

Press  to exit setup menu (if no button is pressed after 2 minutes the menu is exited automatically).

ID	Description	Limits	Resolution	Standard setup
ton	Ton – drain time ON : time ON condensate drain valve 00 = Electronic drainer installed	00 ... 20 sec	1 sec	00
tof	ToF - drain time OFF : pause time for condensate drain valve	1 ... 20 min	1 min	1
HdA	HdA - High DewPoint Alarm : Alarm threshold for a high DewPoint (the alarm disappears when the temperature drop 1°C / 2°F below alarm point)	0.0...25.0 °C or 32 ... 77 °F	0.5 °C or 1 °F	20 or 68
Hdd	Hdd - High DewPoint Delay : high DewPoint alarm enable delay	01 ... 20 minutes	1 min	15
HdS	HdS - High DewPoint alarm STOP : select if high DewPoint alarm stops dryer (YES) or does not stop dryer (nO)	YES ... nO	-	nO
SrL	SrV - Service Setting: setting of service warning timer. 00 = service warning timer disabled.	0.0 ... 9.0 (x 1000) hours	0.5 (x1000) hours	8.0
SCL	SCL - Scale: display scale of temperatures and pressure. (Note : setting °C = temperature in °C and pressure in bar; setting °F = temperature in °F and pressure in psi)	°C ... °F	-	°F
AS	AS - Auto Restart : automatic re-start at power supply. YES = at power supply dryer starts up again automatically (if it was ON) nO = at power supply dryer is always OFF	YES ... nO	-	nO
Ard	Ard - Auto Reset service drain : automatic reset of service drain YES = automatic reset at normal conditions nO = manual reset required	YES ... nO	-	YES
IPR	IPA - IP Address : selection of IP address to use in serial connection line	1 ... 255	1	1



AS = YES - CAUTION - THE DRYER MAY POWER UP WITHOUT BEING ACTED UPON. THE USER WILL BE RESPONSIBLE FOR THE INSTALLATION OF PROPER PROTECTIONS FOR POSSIBLE SUDDEN POWER RESTORATION TO THE DRYER.

7.16 Electronic drainer

This drain consists of a condensate accumulator where a capacitive sensor continuously checking liquid level is placed: as soon as the accumulator is filled, the sensor passes a signal to the electronic control and a diaphragm solenoid valve will open to discharge the condensate. For a complete condensate discharge the valve opening time will be adjusted exactly for each single drain operation. No condensate strainers are installed. No adjusting is required. A service valve is installed before the electronic drain in order to make check and maintenance easily. **At dryer start-up verify that this valve is open.**

Control panel

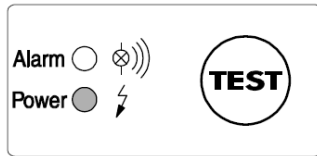

- Power Led On - drainer ready to work / supplied
- Alarm Led Blinking - drainer in alarm condition
- TEST Button Discharge test (keep pushed for 2 seconds)

Troubleshooting



Only qualified personnel should perform troubleshooting and or maintenance operations.

Prior to performing any maintenance or service, be sure that :



- no part of the machine is powered and that it cannot be connected to the mains supply.
- no part of the machine is under pressure and that it cannot be connected to the compressed air system.
- maintenance personnel have read and understand the safety and operation instructions in this manual.

SYMPTOM	POSSIBLE CAUSE - SUGGESTED ACTION
◆ No led lighting up.	<ul style="list-style-type: none"> ⇒ Verify that the system is powered. ⇒ Verify the electric wiring (internal and/or external). ⇒ Check internal printed circuit board for possible damage.
◆ Pressing of Test button, but no condensate discharge.	<ul style="list-style-type: none"> ⇒ The service valve located before the drain is closed - open it. ⇒ The dryer is not under pressure - restore nominal condition. ⇒ Solenoid valve defective - replace the drain. ⇒ The internal printed circuit board is damaged - replace the drain.
◆ Condensate discharge only when Test button is pressed.	<ul style="list-style-type: none"> ⇒ The capacitive sensor is too dirty - open the drain and clean the sensor plastic tube.
◆ Drain keeps blowing off air.	<ul style="list-style-type: none"> ⇒ The diaphragm valve is dirty - open the drain and clean it. ⇒ The capacitive sensor is too dirty - open the drain and clean the sensor plastic tube.
◆ Drain in alarm condition.	<ul style="list-style-type: none"> ⇒ The capacitive sensor is too dirty - open the drain and clean the sensor plastic tube. ⇒ The service valve located before the drain is closed - open it. ⇒ The dryer is not under pressure - restore nominal condition. ⇒ Solenoid valve defective - replace the drain.

NOTE : When the drain is in alarm condition, the diaphragm solenoid valve will open 7.5 sec every 4 min.

8 Maintenance, troubleshooting, spare parts and dismantling

8.1 Checks and maintenance



Only qualified personnel should perform troubleshooting and or maintenance operations.

Prior to performing any maintenance or service, be sure that :



- no part of the machine is powered and that it cannot be connected to the mains supply.
- no part of the machine is under pressure and that it cannot be connected to the compressed air system.
- maintenance personnel have read and understand the safety and operation instructions in this manual.



Before attempting any maintenance operation on the dryer, shut it down and wait at least 30 minutes. components can reach high temperature during operation. Avoid contact until system or component has dissipated heat.

Daily



- Verify that the DewPoint displayed on the electronic instrument is correct.
- Check the proper operation of the condensate drain systems.
- Verify the condenser for cleanliness (Air-Cooled).

Every 200 hours or monthly



- With an air jet (max. 2 bar / 30 psig) blowing from inside towards outside clean the condenser; repeat this operation blowing in the opposite way; be careful not to damage the aluminum fins of the cooling package (Air-Cooled)



- Close the manual condensate drain valve, unscrew the strainer (if installed) and clean it with compressed air and brush. Reinstall the strainer properly tight, and then open the manual valve.
- At the end, check the operation of the machine

Every 1000 hours or yearly



- Verify for tightness all the screws of the electric system and that all the “Disconnects-Tabs” type connections are in their proper position inspect unit for broken, cracked or bare wires.
- Inspect refrigerating circuit for signs of oil and refrigerant leakage.
- Measure and record amperage. Verify that readings are within acceptable parameters as listed in specification table.
- Inspect flexible hoses, and replace if necessary.
- At the end, check the operation of the machine.

Every 8000 hours



- Replace Electronic drainer service unit

8.2 Troubleshooting



Only qualified personnel should perform troubleshooting and or maintenance operations.



Prior to performing any maintenance or service, be sure that :



- no part of the machine is powered and that it cannot be connected to the mains supply.
- no part of the machine is under pressure and that it cannot be connected to the compressed air system.
- maintenance personnel have read and understand the safety and operation instructions in this manual.













Before attempting any maintenance operation on the dryer, shut it down and wait at least 30 minutes. Some components can reach high temperature during operation. Avoid contact until system or component has dissipated heat.

SYMPTOM	POSSIBLE CAUSE - SUGGESTED ACTION
◆ The dryer doesn't start.	<ul style="list-style-type: none"> ⇒ Verify that the system is powered. ⇒ Verify the electric wiring. ⇒ Blow of fuse (see FU1/FU2/FU4 on the electric diagram) of the auxiliary circuit - replace it and check the proper operation of the dryer. ⇒ DMC24 - The led  is lighted - see specific point.
◆ The compressor doesn't work.	<ul style="list-style-type: none"> ⇒ Activation of the compressor internal thermal protection - wait for 30 minutes, then retry. ⇒ Verify the electric wiring. ⇒ DMC24 - Internal delay device – the display shows the seconds before start-up. ⇒ DMC24 - The led  is lighted - see specific point. ⇒ If the compressor still doesn't work, replace it.
◆ Condenser's fan doesn't work (Air-Cooled).	<ul style="list-style-type: none"> ⇒ Verify the electric wiring. ⇒ Fan power contactor (see KV1/KV2 on the electric diagram) is faulty - replace it. ⇒ DMC24 - The led  is lighted - see specific point. ⇒ There is a leak in the refrigerant circuit - contact a refrigeration engineer. ⇒ If the fan still doesn't work, replace it.
◆ DewPoint too high.	<ul style="list-style-type: none"> ⇒ The dryer doesn't start - see specific point. ⇒ The DewPoint probe doesn't correctly detect the temperature - ensure the sensor is pushed into the bottom of probe well. ⇒ The Compressor doesn't work - see specific point. ⇒ The ambient temperature is too high or the room aeration is insufficient - provide proper ventilation (Air-Cooled). ⇒ The inlet air is too hot - restore nominal conditions. ⇒ The inlet air pressure is too low - restore nominal conditions. ⇒ The inlet air flow rate is higher than the rate of the dryer - reduce the flow rate - restore nominal conditions. ⇒ The condenser is dirty - clean it (Air-Cooled) ⇒ The condenser fan doesn't work - see specific point (Air-Cooled). ⇒ The cooling water is too hot - restore nominal conditions (Water-Cooled). ⇒ The cooling water flow is insufficient - restore nominal conditions (Water-Cooled). ⇒ The dryer doesn't drain the condensate - see specific point. ⇒ The hot gas by-pass valve is out of setting - contact a refrigeration engineer to restore nominal setting. ⇒ There is a leak in the refrigerant circuit - contact a refrigeration engineer.

SYMPTOM	POSSIBLE CAUSE - SUGGESTED ACTION
◆ Dew Point too low	<ul style="list-style-type: none"> ⇒ The fan is always on – verify the correct operation of the fan power contactor (see KV1/KV2 on the electric diagram) and/or of pressure transducer (see BHP on the electric diagram) – (Air-Cooled). ⇒ Ambient temperature is too low - restore nominal conditions (Air-Cooled). ⇒ The hot gas by-pass valve is out of setting - contact a refrigeration engineer to restore nominal setting.
◆ Excessive pressure drop within the dryer.	<ul style="list-style-type: none"> ⇒ The dryer doesn't drain the condensate - see specific point. ⇒ The DewPoint is too low - the condensate is frost and blocks the air - see specific point. ⇒ Check for throttling the flexible connection hoses.
◆ The dryer doesn't drain the condensate	<ul style="list-style-type: none"> ⇒ The condensate drain service valve is closed - open it. ⇒ Verify the electric wiring. ⇒ The DewPoint is too low - the condensate is frost and blocks the air - see specific point. ⇒ Inlet compressed air pressure is too low and condensate is not drained – restore nominal conditions. ⇒ Electronic drainer is not operating correctly (see paragraph 7.16).
◆ The dryer continuously drains condensate.	<ul style="list-style-type: none"> ⇒ Electronic drainer is dirty (see paragraph 7.16).
◆ Water within the line.	<ul style="list-style-type: none"> ⇒ The dryer doesn't start - see specific point. ⇒ If installed - Untreated air flows through the by-pass unit - close the by-pass. ⇒ The dryer doesn't drain the condensate - see specific point. ⇒ DewPoint too high - see specific point.
◆ HPS high pressure switch has been activated.	<ul style="list-style-type: none"> ⇒ Check which of the following has caused the activation : <ol style="list-style-type: none"> 9. The ambient temperature is too high or the room aeration is insufficient - provide proper ventilation (Air-Cooled). 10. The condenser is dirty - clean it (Air-Cooled). 11. The condenser fan doesn't work - see specific point (Air-Cooled). 12. The cooling water is too hot - restore nominal conditions (Water-Cooled). 13. The cooling water flow is insufficient - restore nominal conditions (Water-Cooled). ⇒ Reset the pressure switch pressing the button on the controller itself - verify the dryer for correct operation. ⇒ HPS pressure switch is faulty - contact a refrigeration engineer to replace it.
◆ LPS low pressure switch has been activated.	<ul style="list-style-type: none"> ⇒ There is a leak in the refrigerating fluid circuit - contact a refrigeration engineer. ⇒ The pressure switch reset automatically when normal conditions are restored - check the proper operation of the dryer.

SYMPTOM	POSSIBLE CAUSE - SUGGESTED ACTION
◆ Compressor discharge temperature too high.	⇒ Check which of the following has caused the failure : <ol style="list-style-type: none"> 1. Excessive thermal load – restore nominal conditions. 2. The inlet air is too hot - restore nominal conditions. 3. The ambient temperature is too high or the room aeration is insufficient - provide proper ventilation (Air-Cooled). 4. The condenser unit is dirty - clean it (Air-Cooled). 5. The fan doesn't work - see specific point (Air-Cooled). 6. The fan is always on – verify proper operation of fan power contactor (see KV1/KV2 on electric diagram) and/or of pressure transducer (see BHP on electric diagram) – (Air-Cooled). 7. The hot gas by-pass valve requires re-adjusting – contact a specialized technician to restore nominal setting. 8. The temperature of the cooling water is too low – restore nominal conditions (Water-Cooled). 9. The cooling water flow adjusting valve requires re-adjusting - contact a specialized technician to restore nominal setting (Water-Cooled). 10. Refrigerant gas leak - contact a refrigeration engineer.
◆ Condensing pressure too high	⇒ Check which of the following has caused the failure : <ol style="list-style-type: none"> 1. The ambient temperature is too high or the room aeration is insufficient - provide proper ventilation (Air-Cooled). 2. The condenser unit is dirty - clean it (Air-Cooled). 3. The fan doesn't work - see specific point (Air-Cooled). 4. The temperature of the cooling water is too hot – restore nominal conditions (Water-Cooled). 5. Cooling water flow is not sufficient – restore nominal conditions (Water-Cooled).
◆ Condensing pressure too low	⇒ Check which of the following has caused the failure : <ol style="list-style-type: none"> 1. The fan is always on – verify proper operation of fan power contactor (see KV1/KV2 on electric diagram) and/or of pressure transducer (see BHP on electric diagram) – (Air-Cooled). 2. Ambient temperature is too low - restore nominal conditions (Air-Cooled). 3. Air flows through the condenser even with fan off – protect dryer against wind or external air flows (not caused by dryer's fan) (Air-Cooled). 4. The temperature of the cooling water is too low – restore nominal conditions (Water-Cooled). 5. The cooling water flow adjusting valve requires re-adjusting - contact a specialized technician to restore nominal setting (Water-Cooled). 6. Refrigerant gas leak - contact a refrigeration engineer. 7. Compressor does not work – see specific point.

SYMPTOM	POSSIBLE CAUSE - SUGGESTED ACTION
<p>◆ Electronic instrument DMC24</p> <p>The led  is on or flashes.</p>	<p>⇒ With  led flashing : one or more alarms are active and the display shows OFF and the active alarms.</p> <p>⇒ With  led lighted : one or more alarms are waiting to be reset and the display shows OFF and the alarms that are no longer active but not yet reset.</p> <p>⇒ The alarms are displayed with the following messages :</p> <ol style="list-style-type: none"> 1. HP : HP - HPS pressure switch tripped (refrigerant high pressure) for condensing pressure too high - see specific paragraph (NOTE : when problem is solved press reset key on HPS pressure switch). 2. LP : LP - LPS pressure switch tripped (low pressure) due to refrigerant pressure too low - see specific paragraph. 3. Con : Con – during first startup – power phases of compressor are not connected properly (see RPP on the electric diagram) – Change rotating direction swapping two phases of the power supply of dryer. These changes have to be done only by a qualified electrician. DO NOT BY PASS RPP PROTECTION: BY OPERATING THE MACHINE IN WRONG ROTATING DIRECTION, THE COMPRESSOR WILL FAIL IMMEDIATELY AND THE WARRANTY WILL BE VOIDED. 4. Con : Con – one phase of power supply of dryer is missing (see RPP on the electric diagram) – restore the missing phase. 5. Con : Con – Reverse Phase Protector (RPP) is faulty – replace it. 6. Con : Con – electric protection of compressor tripped (see Q1/QC1 on the electric diagram)– reset and verify the dryer’s proper operation. 7. Con : Con - if installed - thermal protection inside the compressor tripped (see MC1 on wiring diagram – wait 30 minutes and try again. 8. FAn : FAn - electric protection of fan tripped (see QV1 on the electric diagram) - reset and verify the dryer’s proper operation (Air-Cooled). 9. FAn : FAn – thermal protection inside the fan/s tripped (see MF on wiring diagram – wait 30 minutes and try again (Air-Cooled). 10. Hdt : Hdt – compressor discharge temperature protection tripped due to very high temperature (probe T4) – see specific paragraph. 11. ICE : ICE – temperature inside exchanger (probe T1) too low – DewPoint is too low - see specific paragraph. 12. LCP : LCP - condensing pressure too low – see specific paragraph. 13. PF4 : PF4 – failure temperature probe T4 (compressor discharge) – verify electric wiring and/or replace probe. 14. PFP : PFP – failure pressure transducer BHP (condensing pressure) – verify electric wiring and/or replace transducer. <p>NOTE: after solving the problem, the alarms must be reset (press the keys   simultaneously for 3 seconds).</p>

SYMPTOM	POSSIBLE CAUSE - SUGGESTED ACTION
<p>◆ Electronic instrument DMC24</p> <p>The led  is on or flashes.</p>	<p>⇒ With  led flashing: one or more service warnings are active.</p> <p>⇒ With  led lighted: one or more service warnings are waiting to be reset. The display shows the DewPoint temperature and the active or not reset service warning.</p> <p>⇒ The service warnings are displayed with the following messages :</p> <ol style="list-style-type: none"> 1. PF 1 : PF1 – temperature probe failure T1 (DewPoint) – verify electric wiring and/or replace probe. 2. PF 2 : PF2 - temperature probe failure T2 (air IN) – verify electric wiring and/or replace probe. 3. PF 3 : PF3 - temperature probe failure T3 (compressor suction) – verify electric wiring and/or replace probe. 4. HdP : Hdp – DewPoint too high (higher than set HdA value) – see specific paragraph. 5. LdP : Ldp - DewPoint too low - see specific paragraph. 6. drn : drn – the condensate drainer does not work properly (DRN contact open- if electronic drainer is installed) - see specific paragraph. 7. SrV : SrV - Service – maintenance notice time expired (parameter SrV) – carry out planned maintenance and reset hour counter. 8. dt : dt – compressor supply temperature too high (probe T4) – see specific paragraph. 9. HCP : HCP – condensing pressure too high – see specific paragraph. <p>NOTE: after solving the problem, the services must be reset (press the keys   simultaneously for at least 3 seconds).</p>

8.3 Spare parts

The suggested spare parts list will enable you to promptly intervene in case of abnormal operation, so avoiding to wait for the spares delivery. In case of failure of other parts, for example inside the refrigerating circuit, the replacement must be worked out by a refrigerating systems specialist or in our factory.

NOTE: To order the suggested spare parts or any other part, it's necessary to quote the data reported on the identification plate.

ID N.	DESCRIPTION	PART NUMBER	SACT-JR & SACT-JF																	
			600	800	900	1000	1250	1500	1750	2000	2500	3000	3750	4000	5000					
2	LPS	Pressure switch	5655NNN084	1	1	1	1	1	1	1	1	1	1	1	1	1	1			
4	HPS	Pressure switch	5655NNN082	1	1	1	1	1	1	1	1	1	1	1	1	1	1			
6	MC	Compressor	5030340004	1																
			5030340005		1															
			5030340006			1														
			5030340008				1													
			5030340010					1												
			5030340011						1	1										
7	Hot gas by-pass valve		5030340012										1							
			5030340050												1					
			5030340052														1			
			5030340053															1	1	
			5030340056																1	
			64140SS151	2	2	2	2	2												
9	MV	Pilot valve	64140SS102							1	1	1	1							
			64140SS105												1					
			64140SS110														1			
			64140SS050															1	1	
			64140SS051																1	1
			64140LL025	1	1															1
10	Filter drier		5250390001	1	1															
			5250390002			1	1	1	1	2	2	2	2	3	3	4	4	4	4	
			6650SSN165	1	1	1	1	1	1	1	1	1	1	1	1	1	1	1	1	1
12	BT	Temperature probe	6650SSN173																	
			6650SSN175																1	1
			6650SSN180																1	1
			5625NNN036	4	4	4	4	4	4	4	4	4	4	4	4	4	4	4	4	4

ID N.	DESCRIPTION	PART NUMBER	SACT-UR & SACT-UF																
			600	800	900	1000	1250	1500	1750	2000	2500	3000	3750	4000	5000				
17	Display module	5620100002	1	1	1	1	1	1	1	1	1	1	1	1	1	1	1	1	
	Main module (air cooled)	5620100003	1	1	1	1	1	1	1	1	1	1	1	1	1	1	1	1	
	Main module (water cooled)	5620100003	1	1	1	1	1	1	1	1	1	1	1	1	1	1	1	1	
	Cable main module to display	5625NNN099	1	1	1	1	1	1	1	1	1	1	1	1	1	1	1	1	
19	Water regulating valve (water cooled)	64335FF005	1	1	1	1	1	1	1	1	1	1	1	1	1	1	1	1	
		64335FF010						1	1	1	1	1	1	1	1	1	1	1	
		64335FF015										1	1	1	1	1	1	1	
21	Electronic drainer	2210BEK002L	1	1	1	1	1	2	2	2	2	2	2	2	2	2	2	2	
	Service unit for electronic drainer	2210BEK056	1	1	1	1	1	2	2	2	2	2	2	2	2	2	2	2	
22	Main switch	5450SZN100	1	1	1	1	1	1	1	1	1	1	1	1	1	1	1	1	
		5450SZN105																	
37	Pressure transducer	5622NNN002	1	1	1	1	1	1	1	1	1	1	1	1	1	1	1	1	
		54443SM152	1	1	1	1	1	1	1	1	1	1	1	1	1	1	1	1	
60	Circuit breaker	54443SM165								1	1	1	1	1	1	1	1	1	
		54443SM195																	
		54443SM152								1	1	1	1	1	1	1	1	1	
		54443SM152																	
		5490CAX060	1	1	1	1	1	1	1	1	1	1	1	1	1	1	1	1	
		5490CAX060									2	2	2	2	2	2	2	2	
FU	Fuse kit	5446FSA103	1	1	1	1	1	1	1	1	1	1	1	1	1	1	1	1	
		5446FSA104																	
KC1-KV1-KV2	Contactor	5454TLT016	3	3	3	3	3	3	3	3	3	3	3	3	3	3	3	3	
		5454TLT025								1	1	1	1	1	1	1	1	1	
		5454TLT016								3	3	3	3	3	3	3	3	3	
		5454TLT033																	
KV1-KV2	Mechanical interlock	5490CAX004																	
		5490INM011	1	1	1	1	1	1	1	1	1	1	1	1	1	1	1	1	
KHP-KDR	Relay	5456REL002	1	1	1	1	1	1	1	1	1	1	1	1	1	1	1	1	
		5456REL005																	
TF	Transformer	5440TFM023	1	1	1	1	1	1	1	1	1	1	1	1	1	1	1	1	
		5440TFM031																	
RPP	Reverse phase protector	5456REL050	1	1	1	1	1	1	1	1	1	1	1	1	1	1	1		

8.4 Maintenance operation on the refrigeration circuit



Maintenance and service on refrigerating systems must be carried out only by certified refrigerating engineers only, according to local rules.

All the refrigerant of the system must be recovered for its recycling, reclamation or destruction.

Do not dispose the refrigerant fluid in the environment.

This dryer comes ready to operate and filled with R407C type refrigerant fluid.



In case of refrigerant leak contact a certified refrigerating engineer. Room is to be aired before any intervention.

If is required to re-fill the refrigerating circuit, contact a certified refrigerating engineers.

Refer to the dryer nameplate for refrigerant type and quantity.

Characteristics of refrigerants used:

Refrigerant	Chemical formula	TLV	GWP
R407C - HFC	R32/125/134a (23/25/52) CHF2CF3/CH2F2/CH2FCF3	1000 ppm	1773.85

8.5 Dismantling of the dryer

If the dryer is to be dismantled, it has to be split into homogeneous groups of materials.



Part	Material
Refrigerant fluid	R407C, Oil
Canopy and Supports	Carbon steel, Epoxy paint
Refrigerating compressor	Steel, Copper, Aluminium, Oil
Alu-Dry Module	Aluminium
Condenser Unit	Aluminium, Copper, Carbon steel
Pipe	Copper
Fan	Aluminium, Copper, Steel
Valve	Brass, Steel
Electronic Level Drain	PVC, Aluminium, Steel
Insulation Material	Synthetic rubber without CFC, Polystyrene, Polyurethane
Electric cable	Copper, PVC
Electric Parts	PVC, Copper, Brass



We recommend to comply with the safety rules in force for the disposal of each type of material.

Refrigerant contains droplets of lubrication oil released by the refrigerating compressor.

Do not dispose this fluid in the environment. It has to be discharged from the dryer with a suitable device and then delivered to a collection centre where it will be processed to make it reusable.

9 Attachments

Exploded views – List of components

- | | |
|---|---|
| <ul style="list-style-type: none"> 1 Alu-Dry module 1.1 Insulation material 2 Refrigerant pressure switch LPS 4 Refrigerant pressure switch HPS 6 Compressor 7 Hot-gas bypass valve 8 Condenser (Air-Cooled) 9 Condenser fan (Air-Cooled) 10 Filter dryer 11 Capillary tube 13 Condensate drain service valve 17 Electronic instrument 18 Condenser (Water-Cooled) 19 Condenser water-regulating valve (Water-Cooled) 20 Refrigerant accumulator 21 Electronic drainer 22 Main switch | <ul style="list-style-type: none"> 36 Liquid separator 37 Refrigerant pressure transducer 51 Front panel 52 Back panel 53 Right lateral panel 54 Left lateral panel 55 Cover 56 Base plate 58 Support beam 59 Support bracket 60 Control panel 65 Condenser filter 66 QE door 81 Flow diagram sticker 83 Refrigerant service valve – H.P. side 84 Refrigerant service valve – L.P. side 100 Autotransformer |
|---|---|

Electric diagrams – List of components

- | | |
|---|---|
| <ul style="list-style-type: none"> MC1 Compressor MV1 - 4 Condensers fans DMC24 Electronic instr. DMC24 – Display module DMC24MA Electronic instr. DMC24 – Main module BT1 - 4 Temperature probes BHP Refrigerant pressure transducer | <ul style="list-style-type: none"> LPS Low pressure switch HPS High pressure switch ELD Electronic drainer QS Main switch with door block RC Compressor crankcase heater RPP Reverse phase protector TR Autotransformer |
| <ul style="list-style-type: none"> NT1 Air-Cooled only NT2 Verify transformer connection according to power supply voltage NT3 Jump if not installed NT4 Provided and wired by customer | <ul style="list-style-type: none"> NT5 Limit of equipment NT6 Timed drain output NT7 Water Cooled only |
| <ul style="list-style-type: none"> BN Brown BU Blue BK Black YG Yellow / Green | <ul style="list-style-type: none"> OR Orange RD Red WH White WH / BK White / Black |

9.1 Dryers dimensions

9.1.1 SACT 600 – 1250

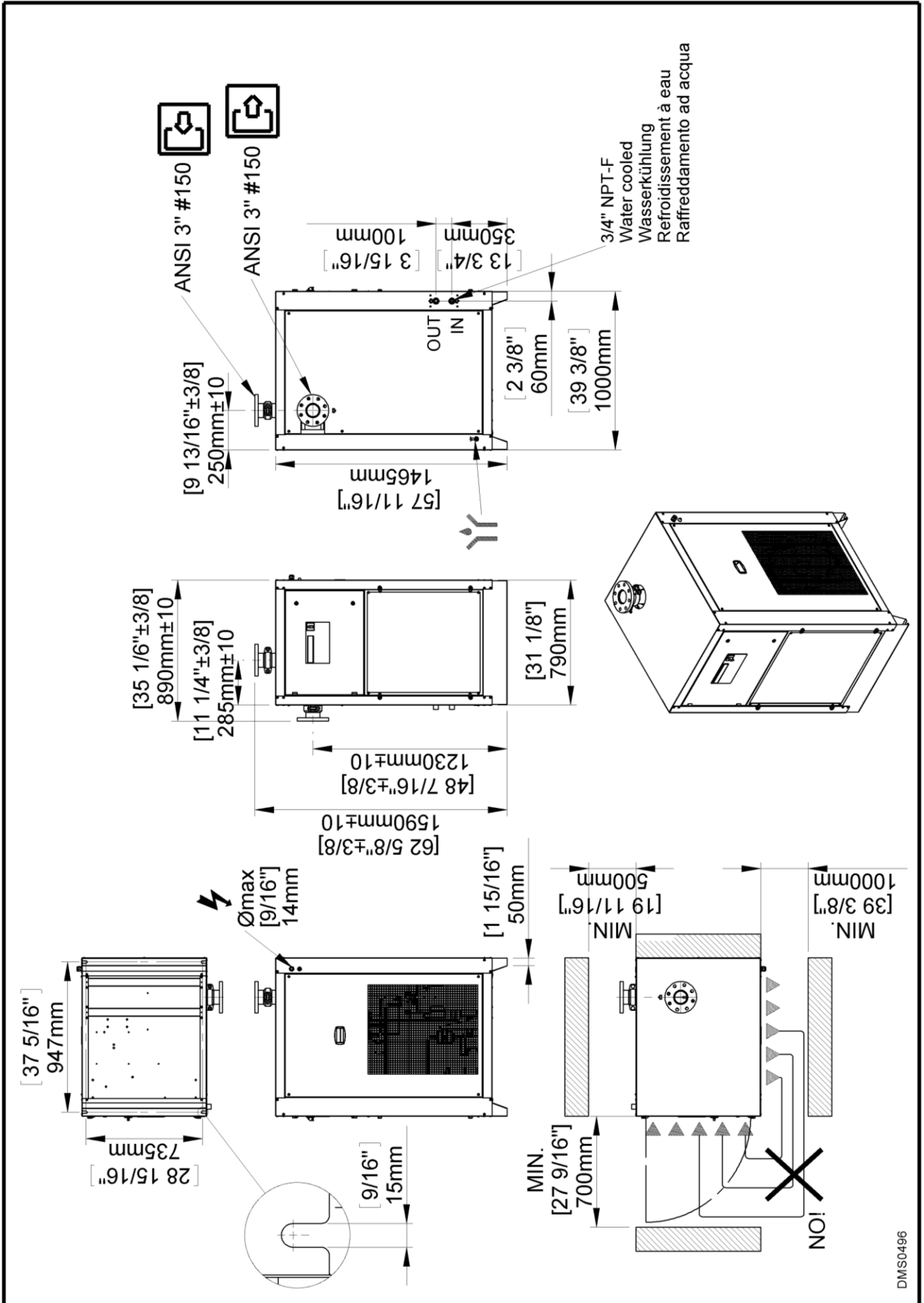

Attachments

9.1.2 SACT 1500 – 2500

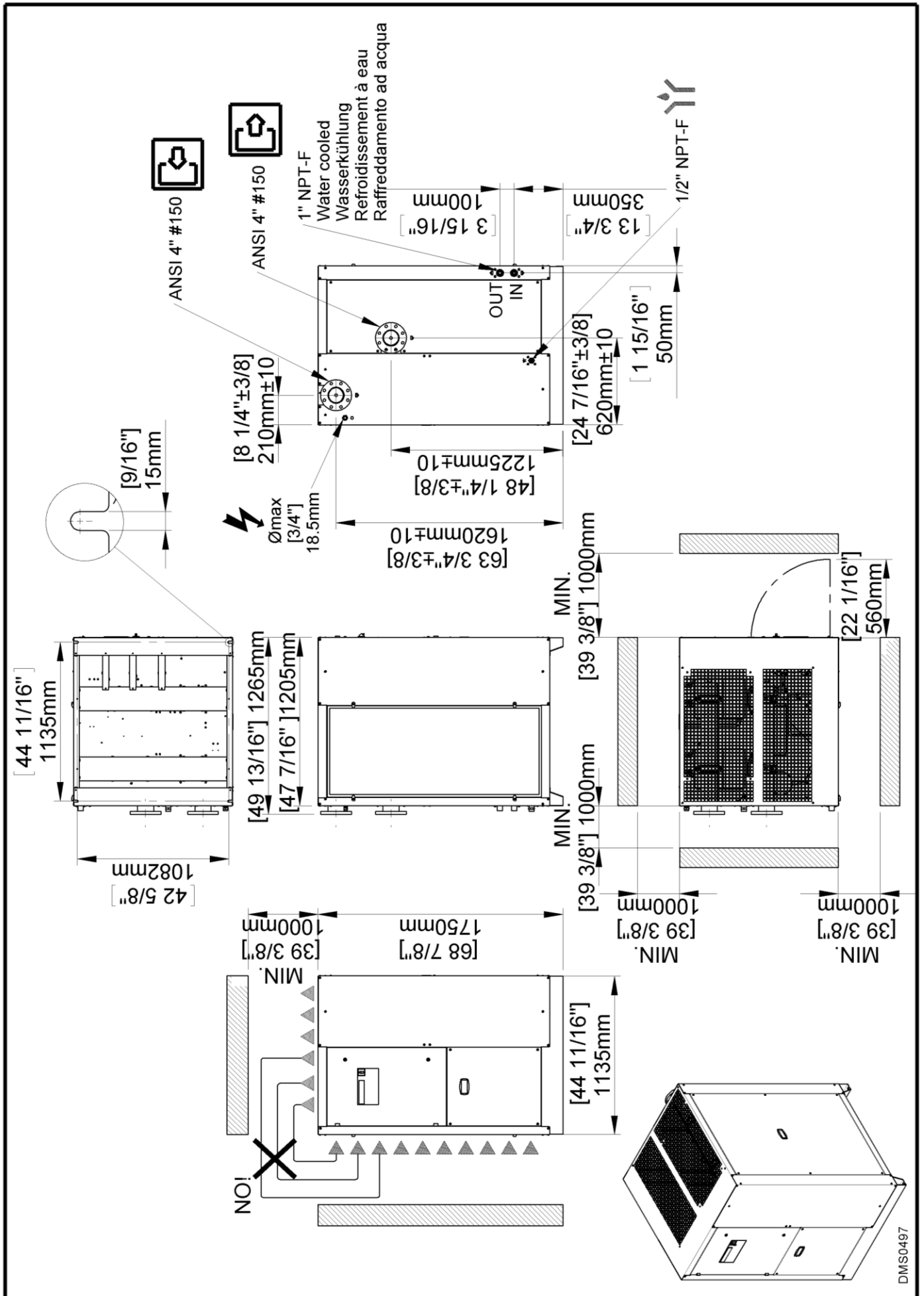

Attachments

9.1.3 SACT 3000 - 3750

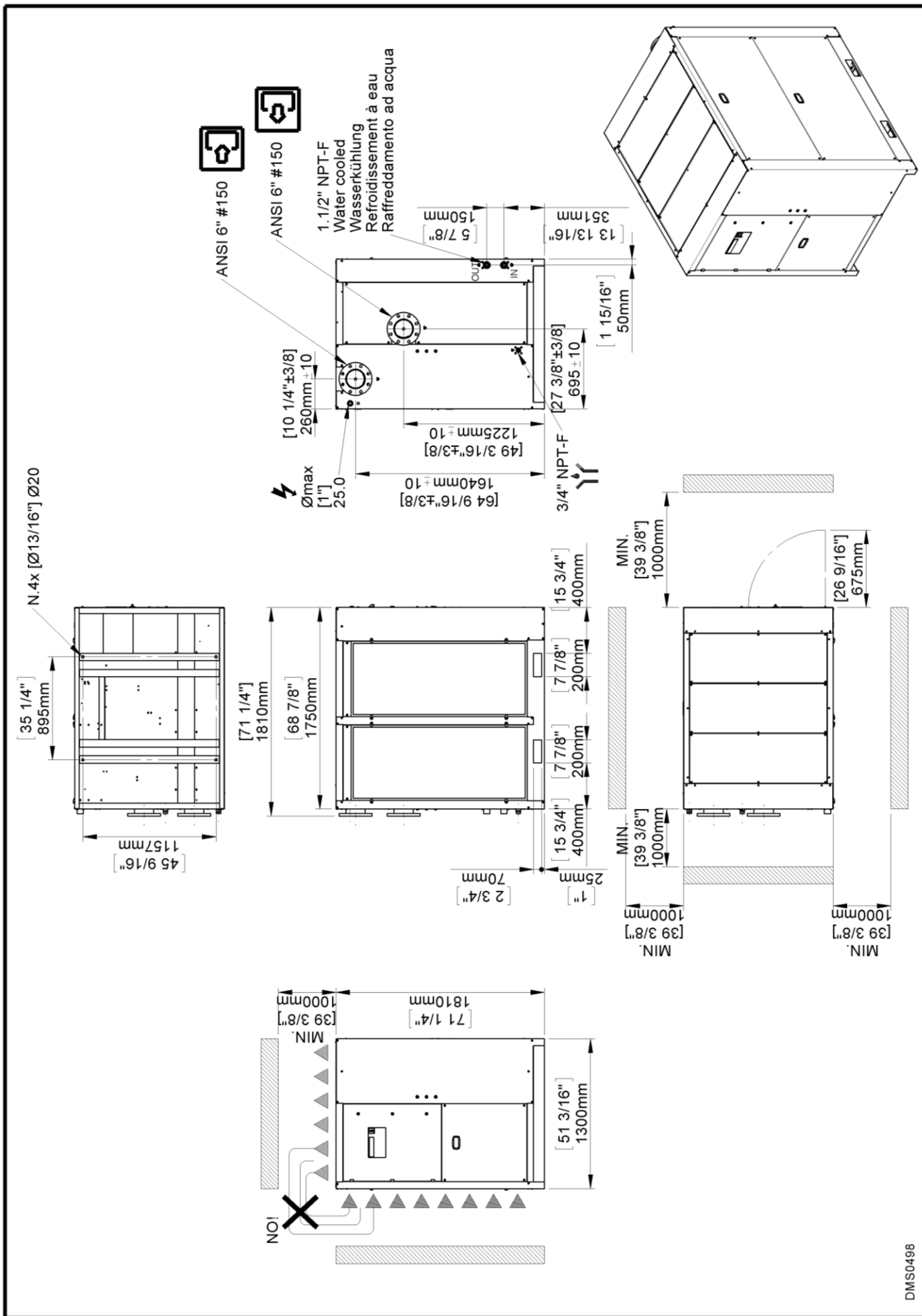

DMS0498

9.1.4 SACT 4000 – 5000

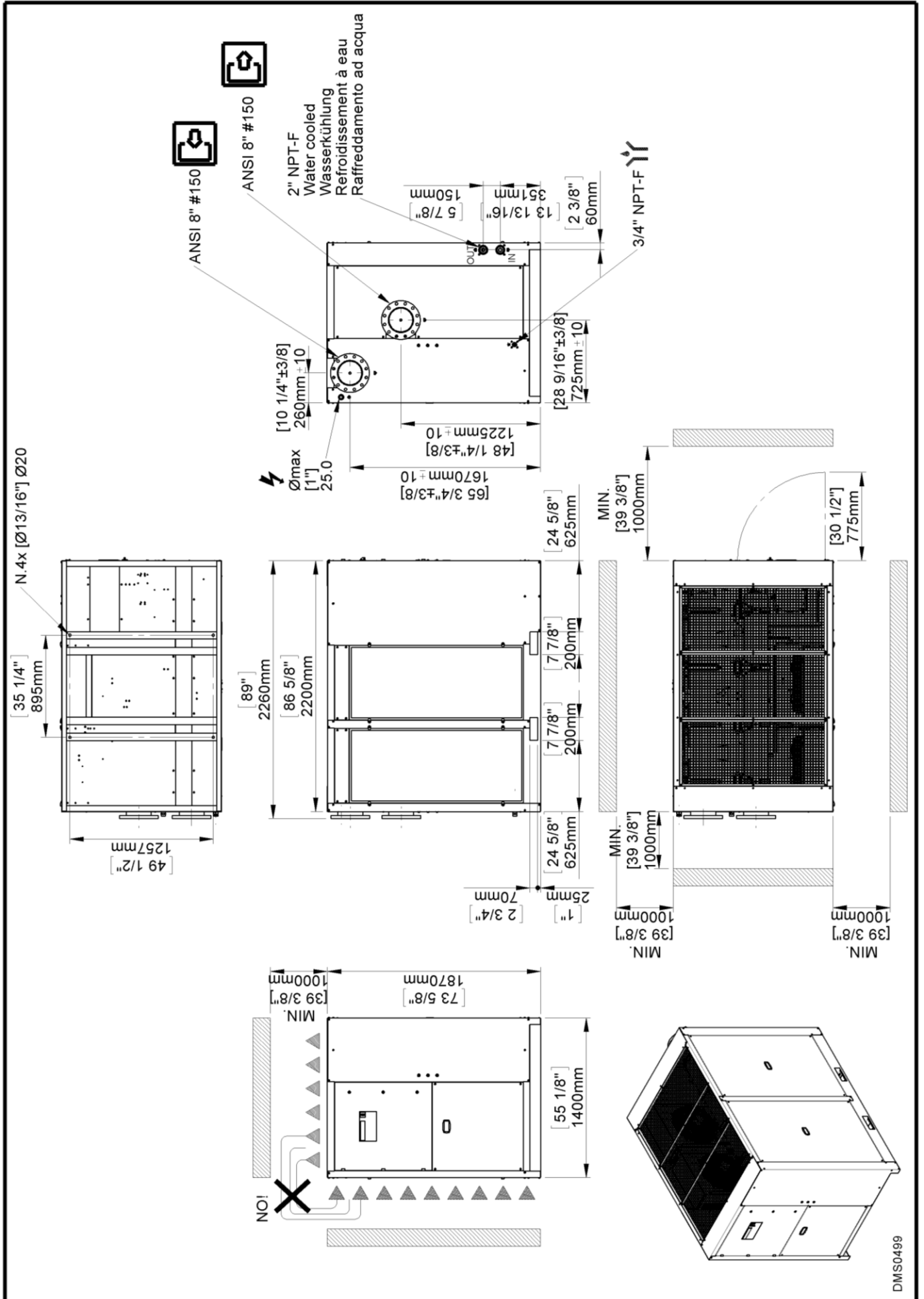

DMS0499

9.2 Exploded views

9.2.1 SACT 600 – 1250 Air Cooled

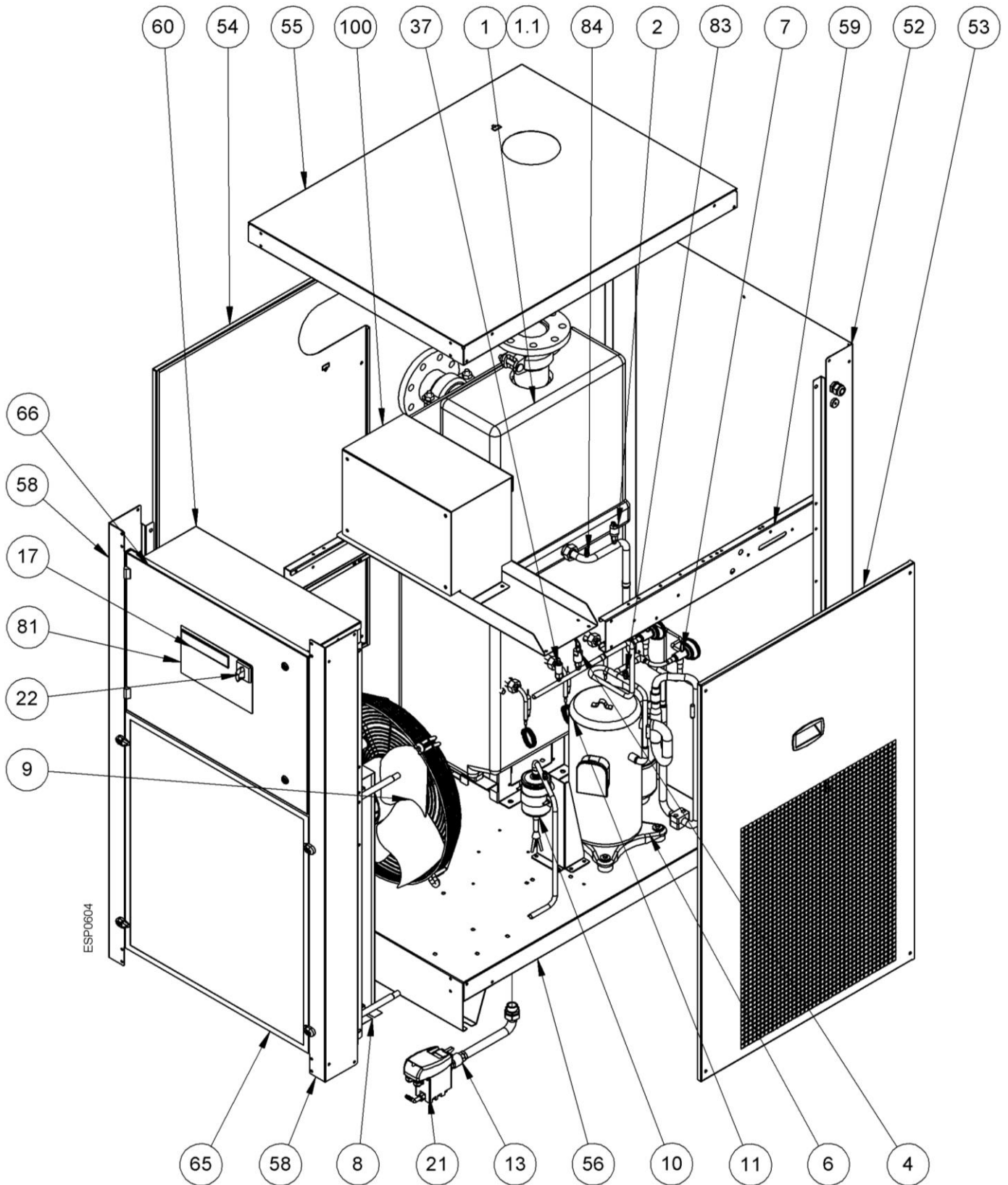

9.2.2 SACT 600 – 1250 Water Cooled

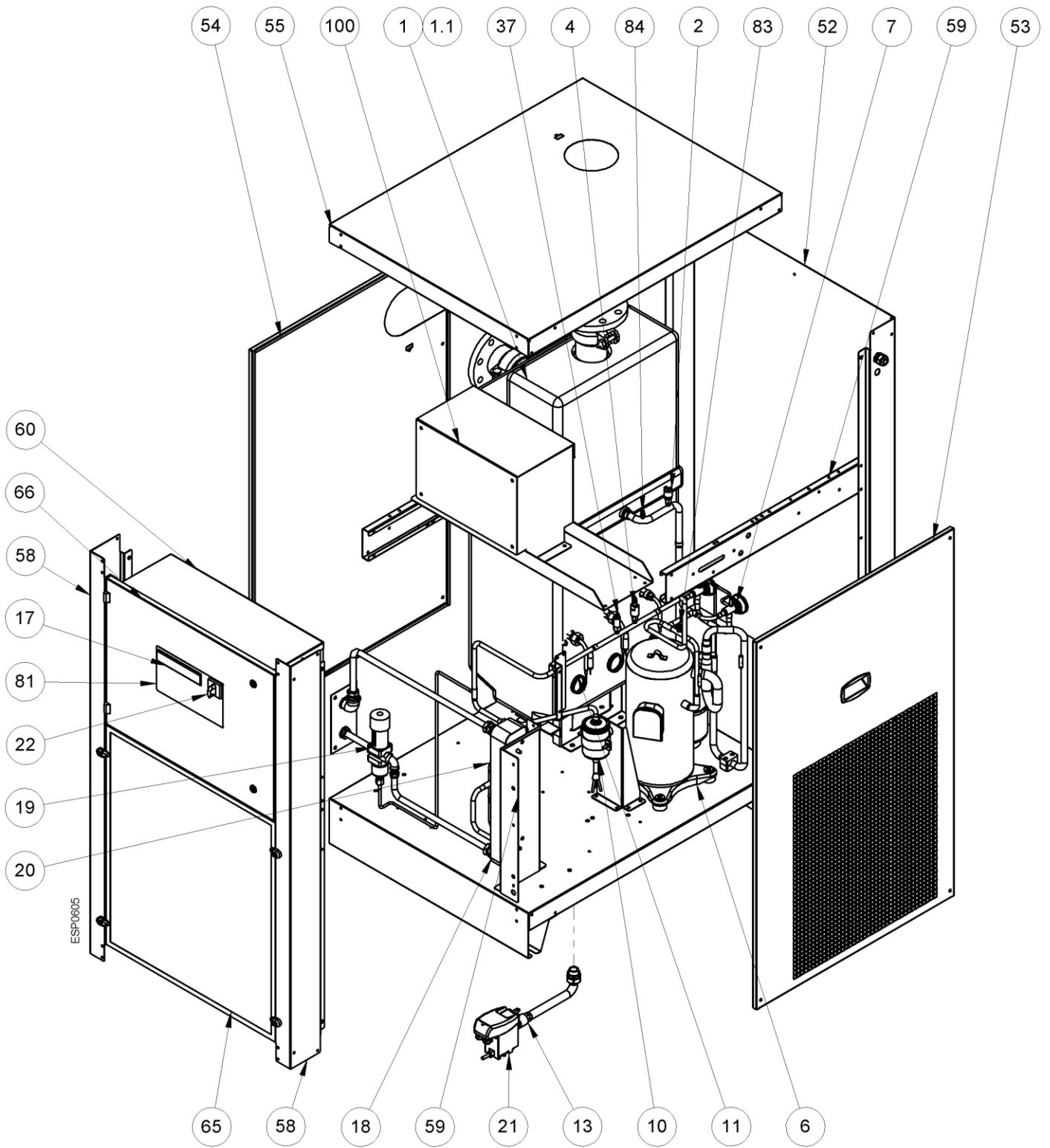

9.2.3 SACT 1500 – 2500 Air Cooled

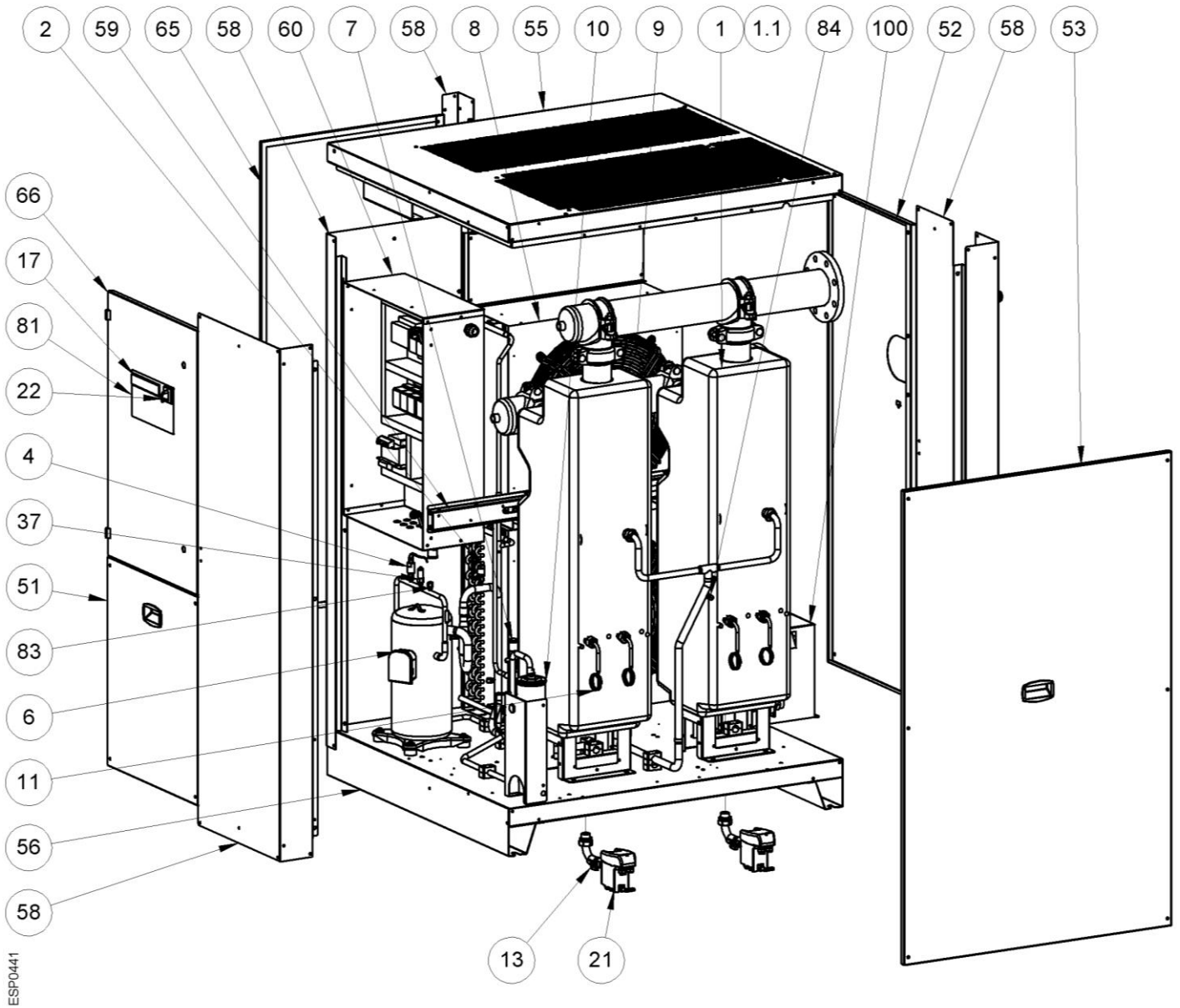

9.2.4 SACT 1500 – 2500 Water Cooled

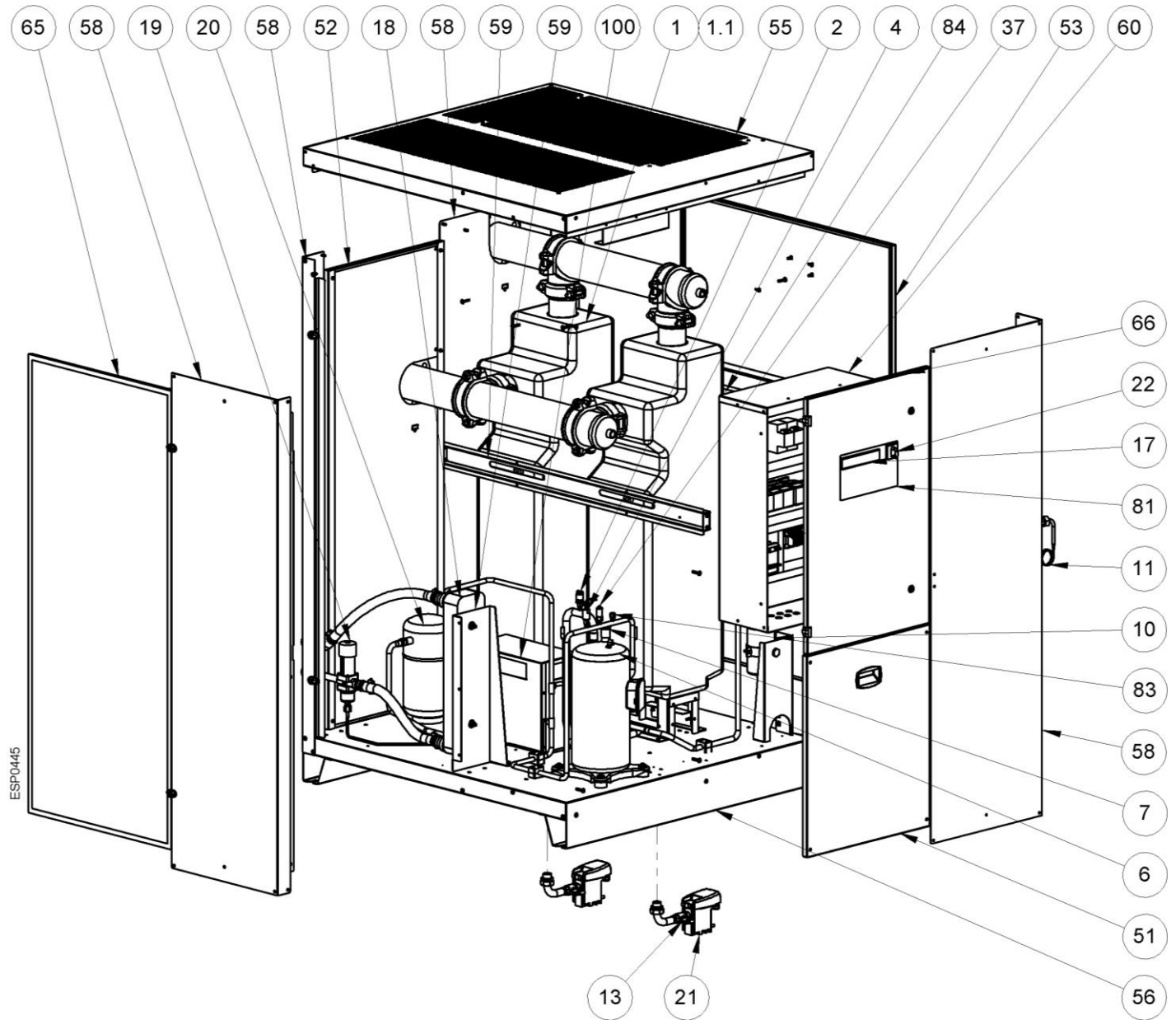

9.2.5 SACT 3000 – 3750 Air Cooled

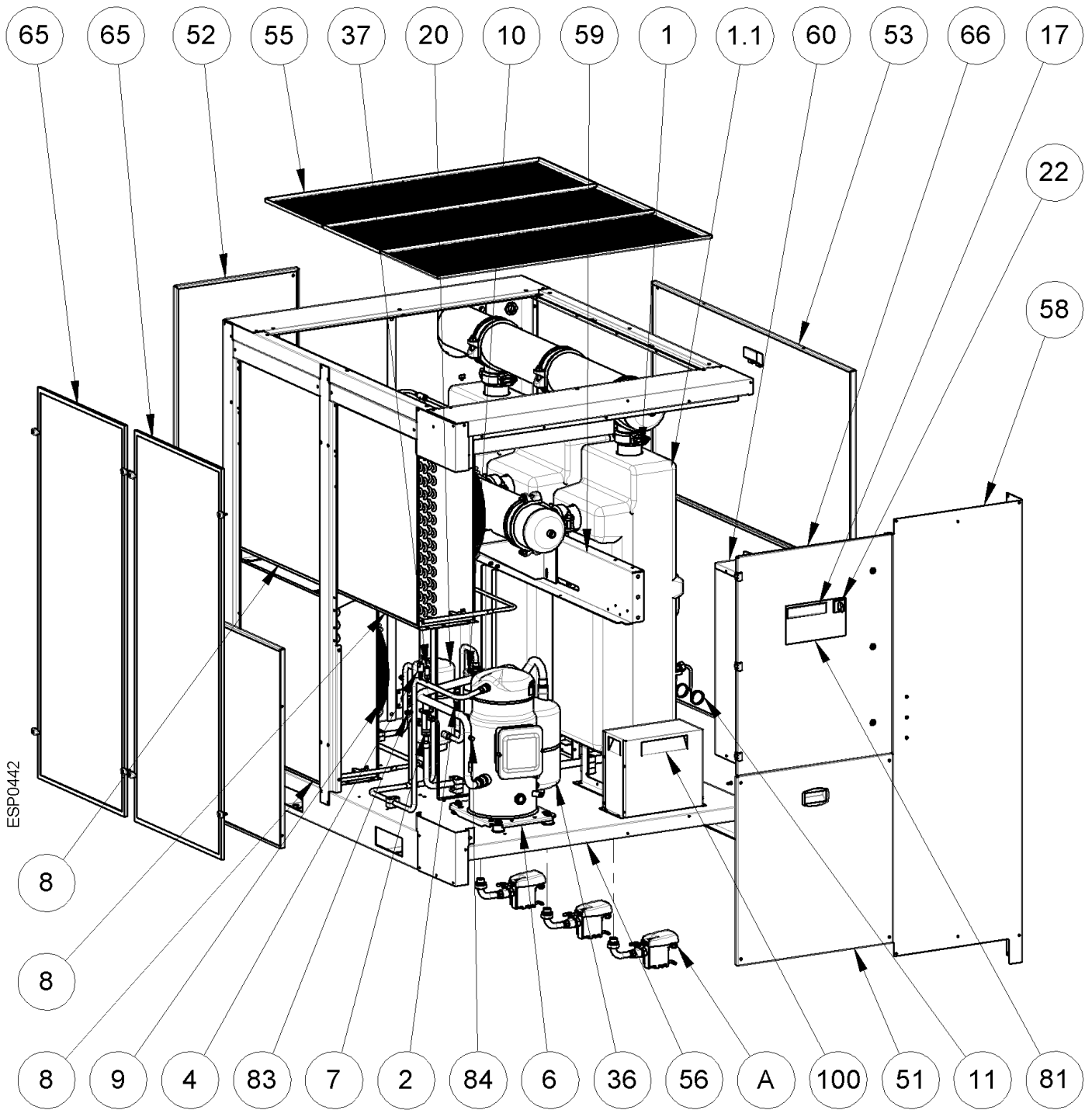

ESP0442

Pos. "A" x3

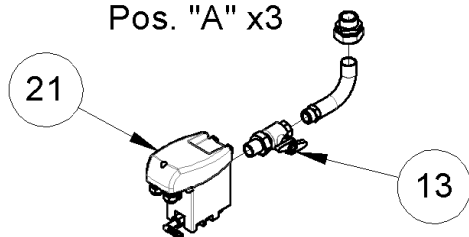

9.2.6 SACT 3000 – 3750 Water Cooled

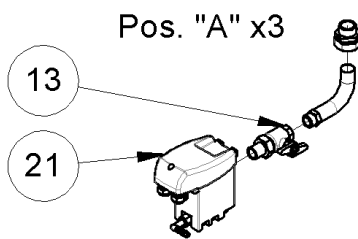
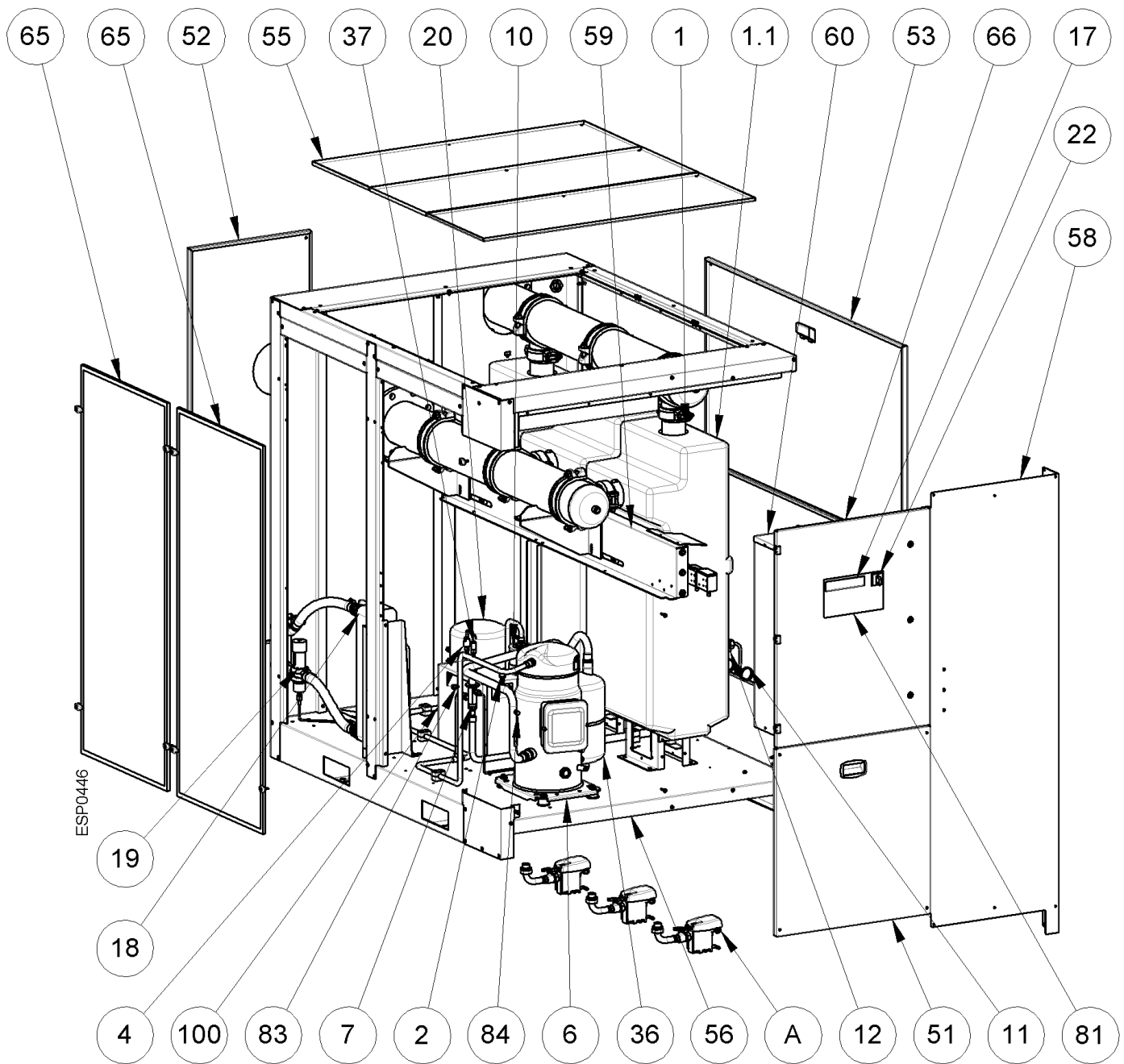

9.2.7 SACT 4000 – 5000 Air Cooled

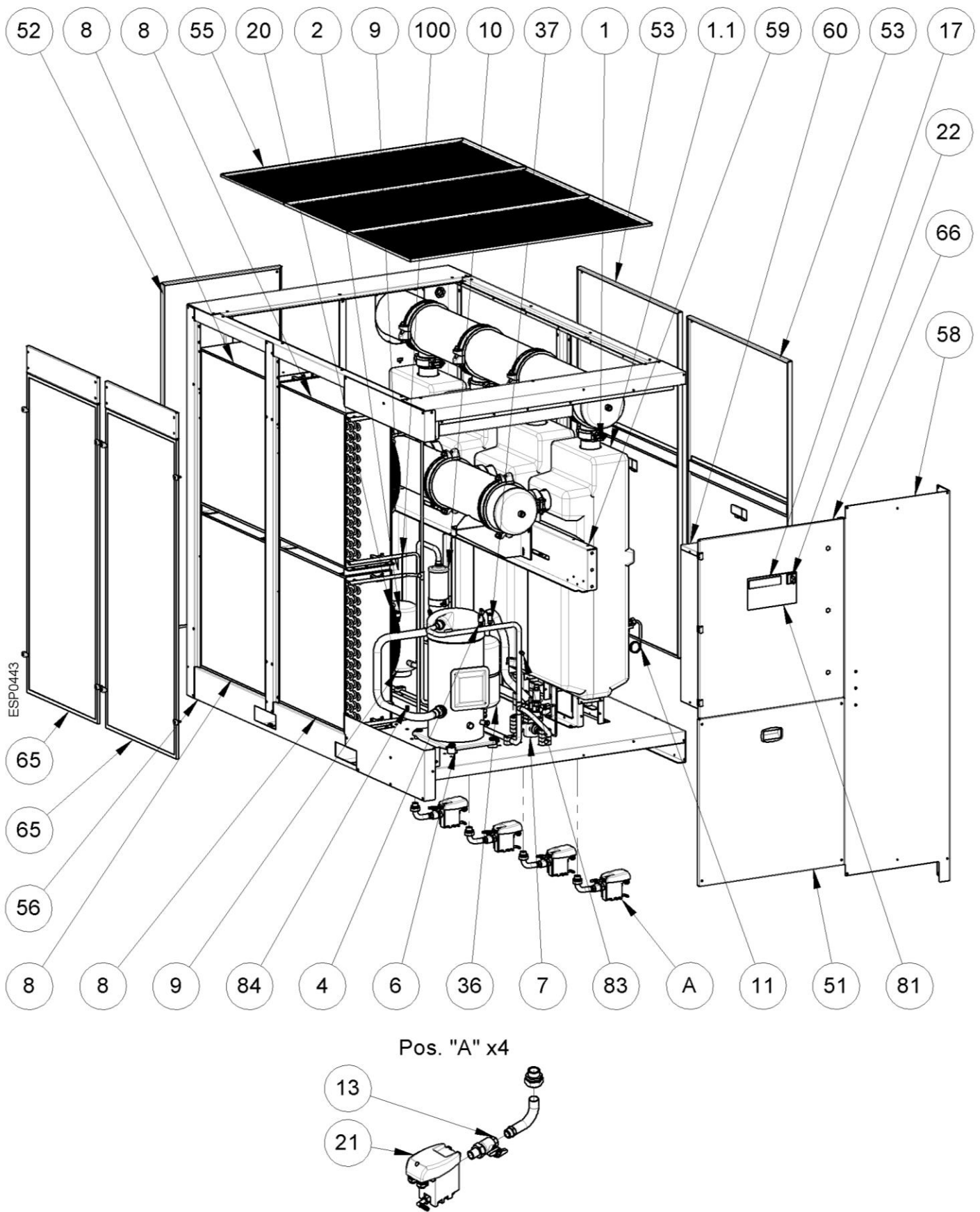

9.2.8 SACT 4000 – 5000 Water Cooled

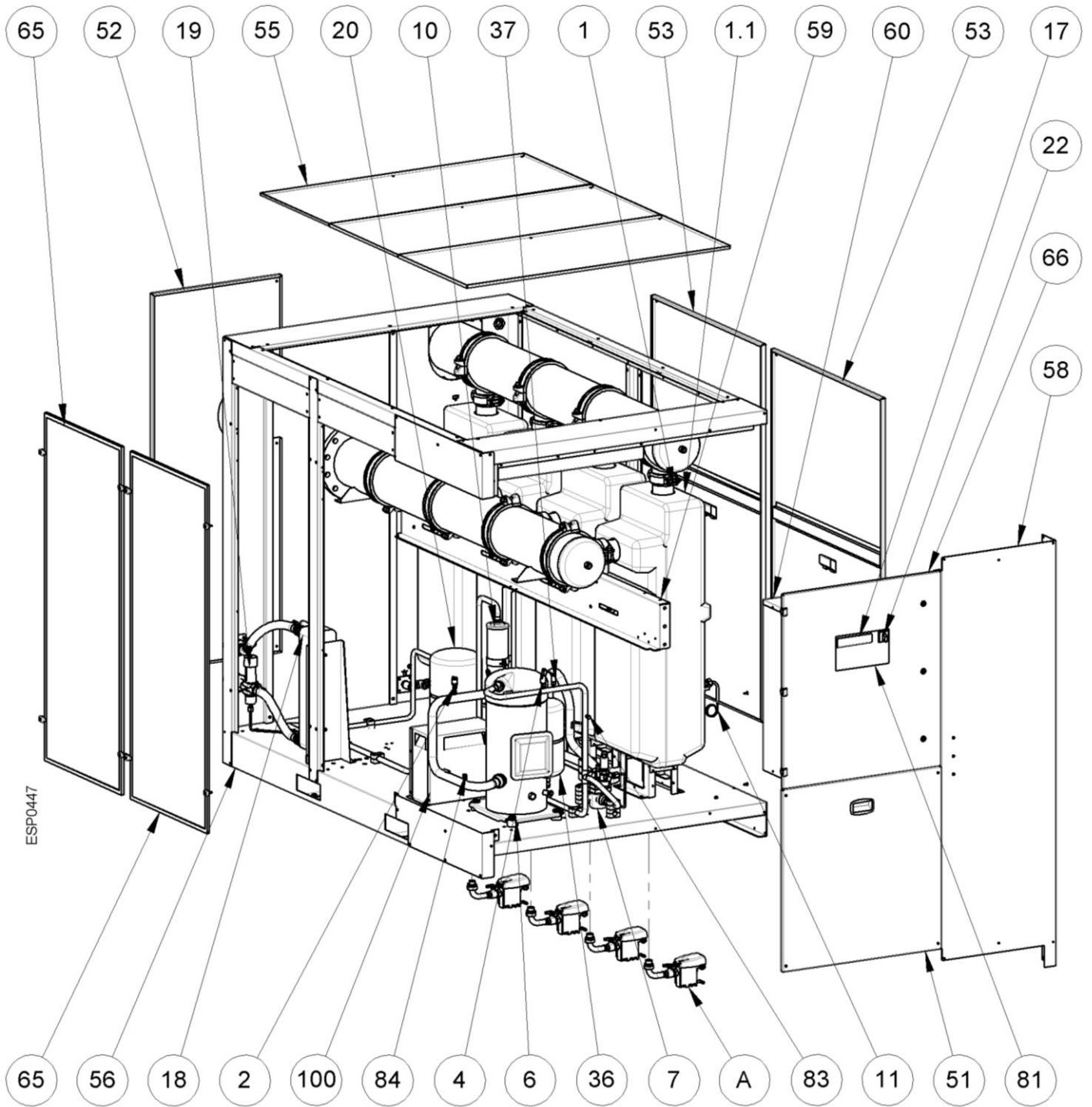

Pos. "A" x4

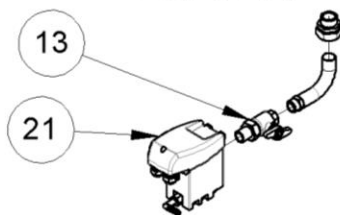

9.3 Electric diagrams

9.3.1 SACT 600 – 1250 Sheet 1 of 3

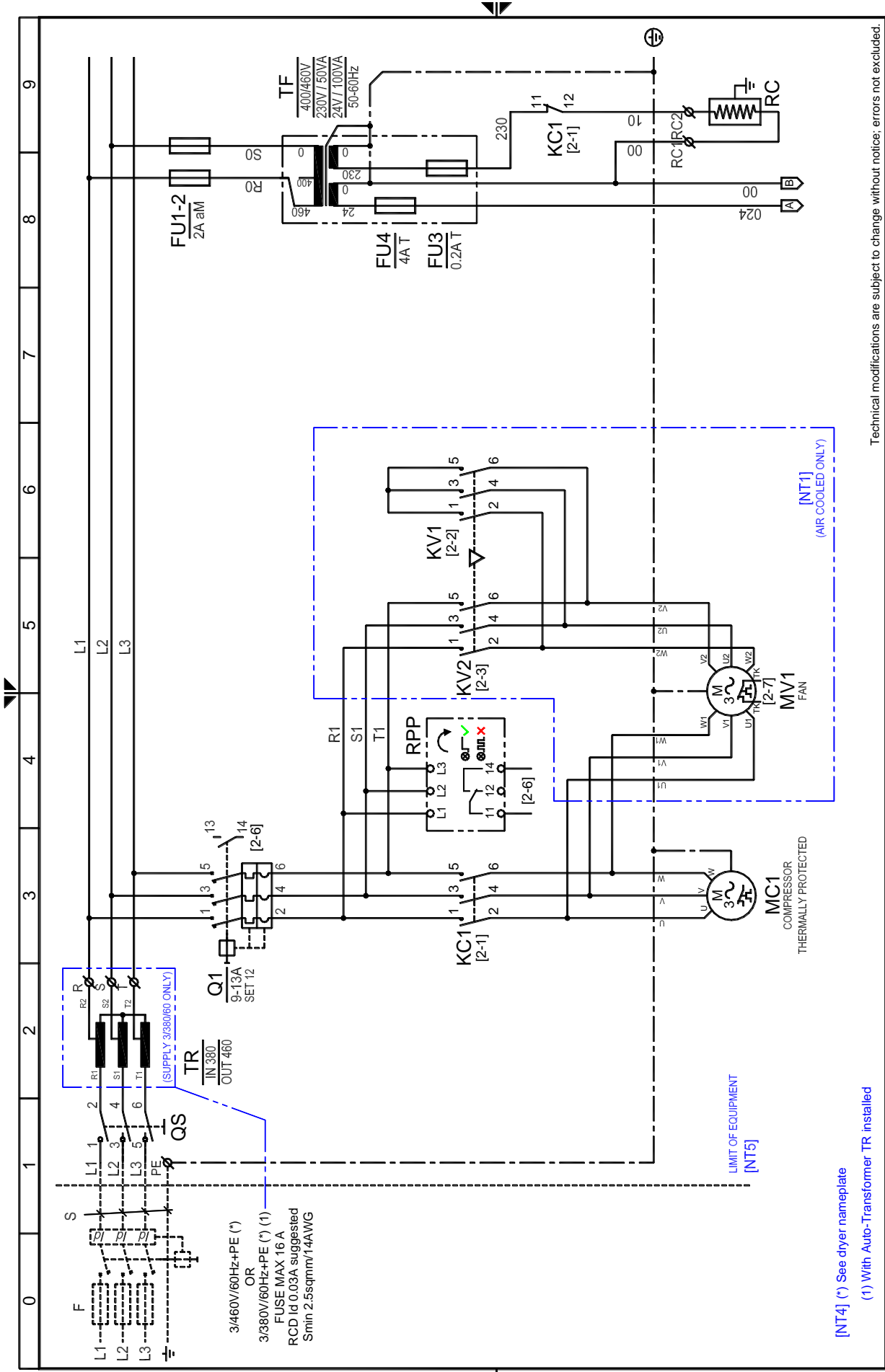

[NT4] (*) See dryer nameplate

(1) With Auto-Transformer TR installed

Technical modifications are subject to change without notice; errors not excluded.

Drawing no. : FRACT-F5478QCD001

Rev. 01

Note :

Sheet 01 of 03

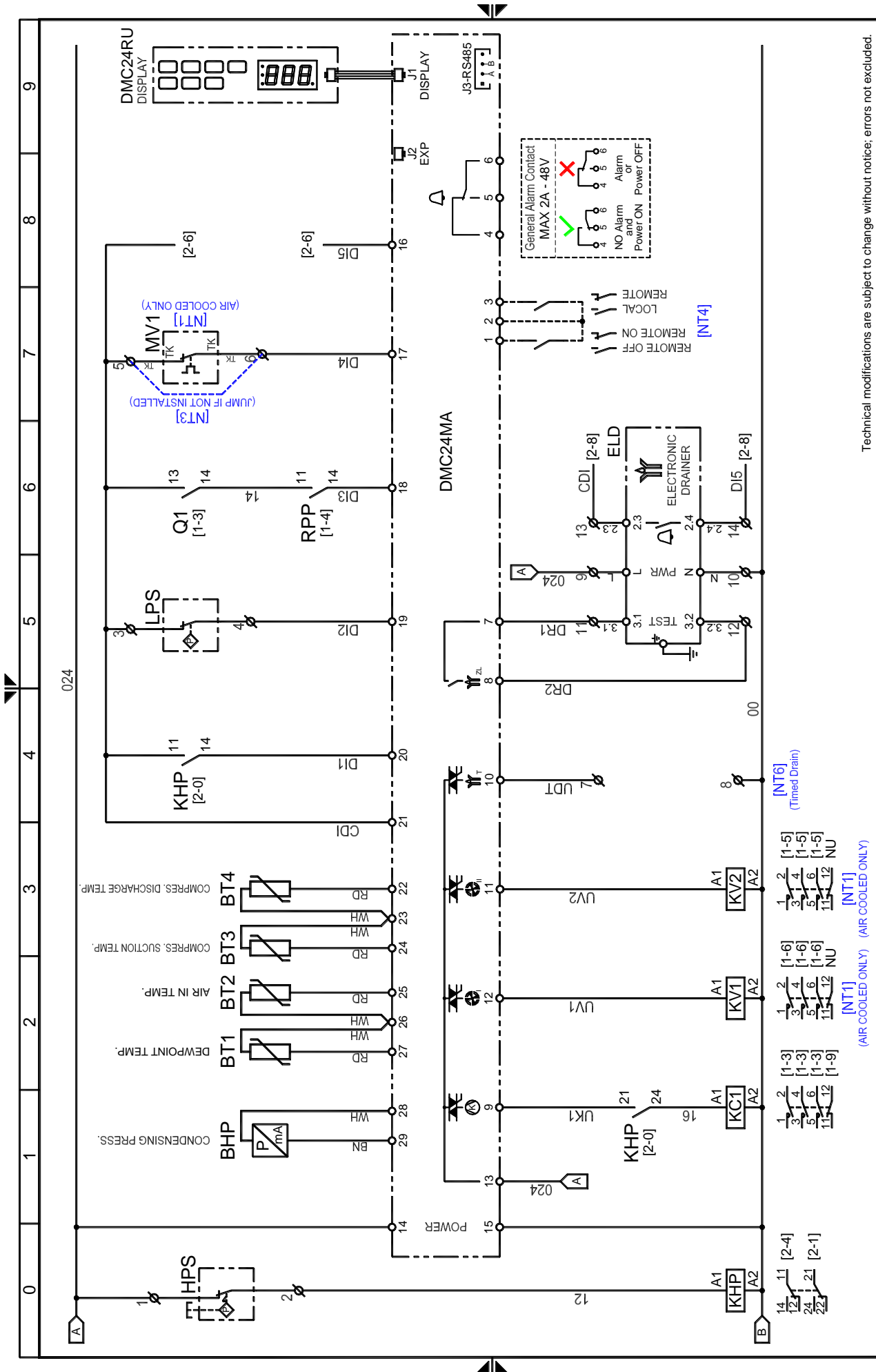

Technical modifications are subject to change without notice; errors not excluded.

Drawing no. : FRACT-F5478QC001

Rev: 01

Note :

Sheet 02 of 03

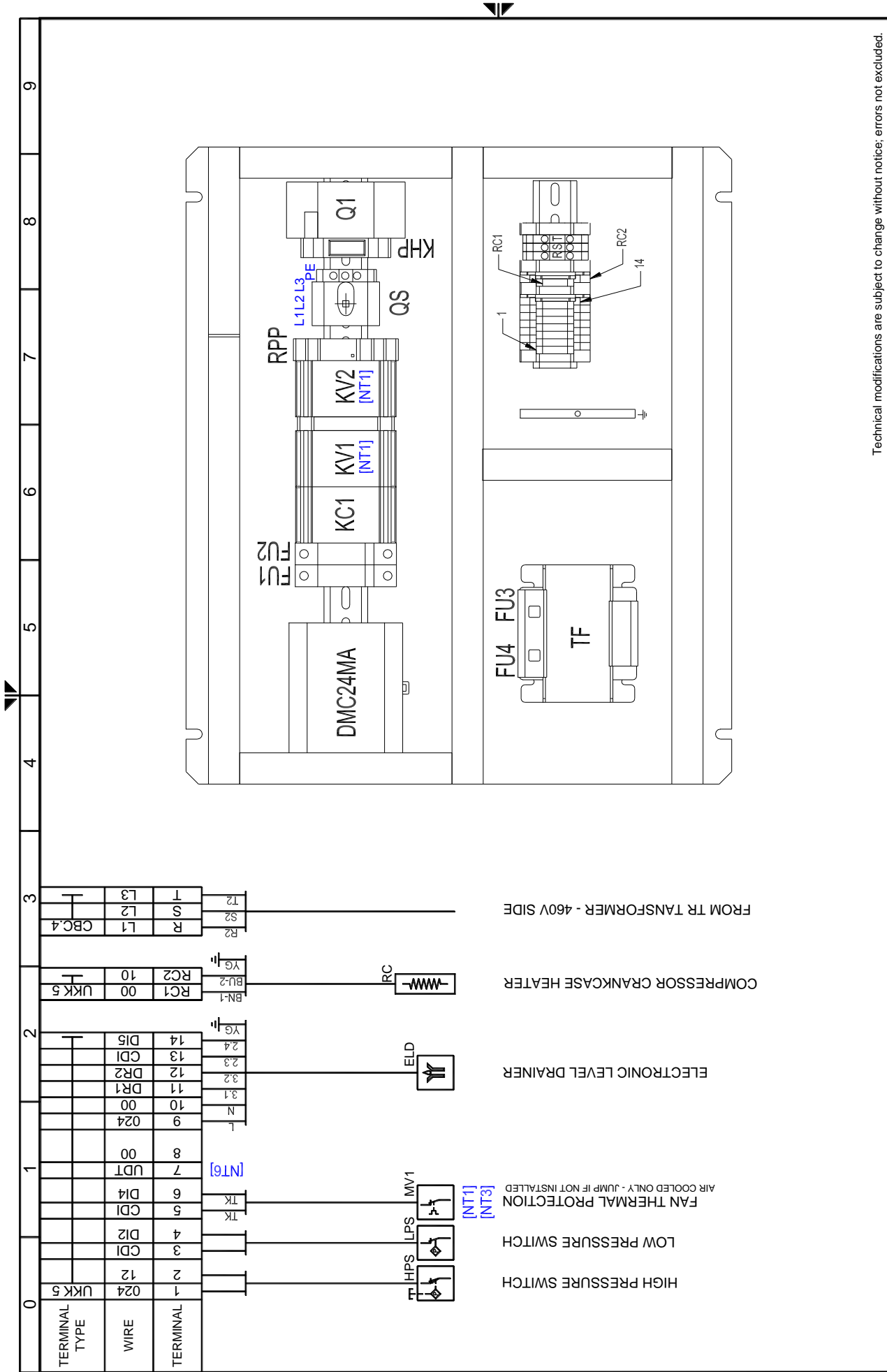

Technical modifications are subject to change without notice; errors not excluded.

Drawing no.: FRACT-F5478QCD001 Rev. 01

Note:

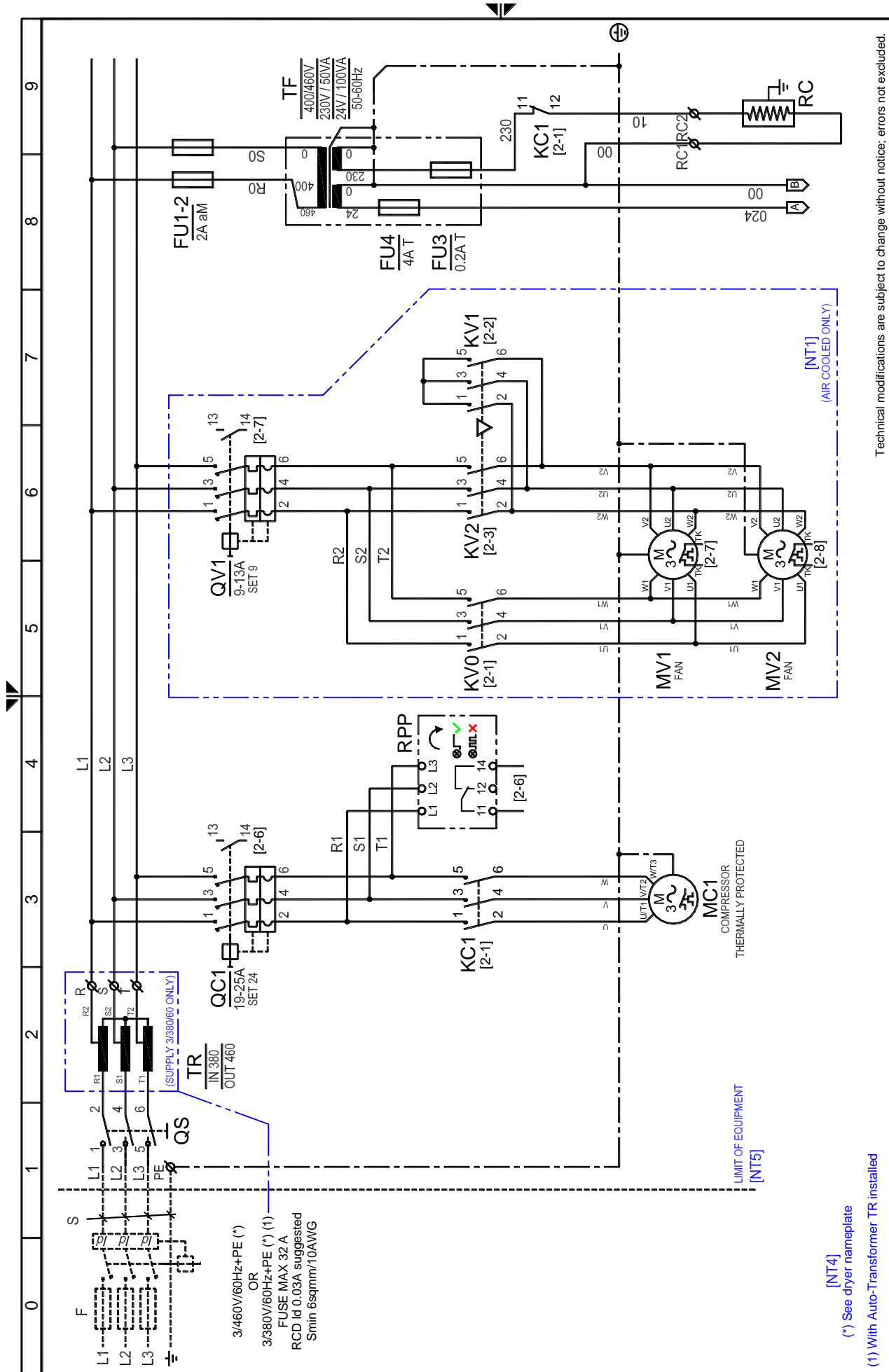

[NT4]

(*) See dryer nameplate

(1) With Auto-Transformer TR installed

Technical modifications are subject to change without notice; errors not excluded.

Rev.

FRACT-F5478QCD002

01

Note :

Sheet 01 of 04

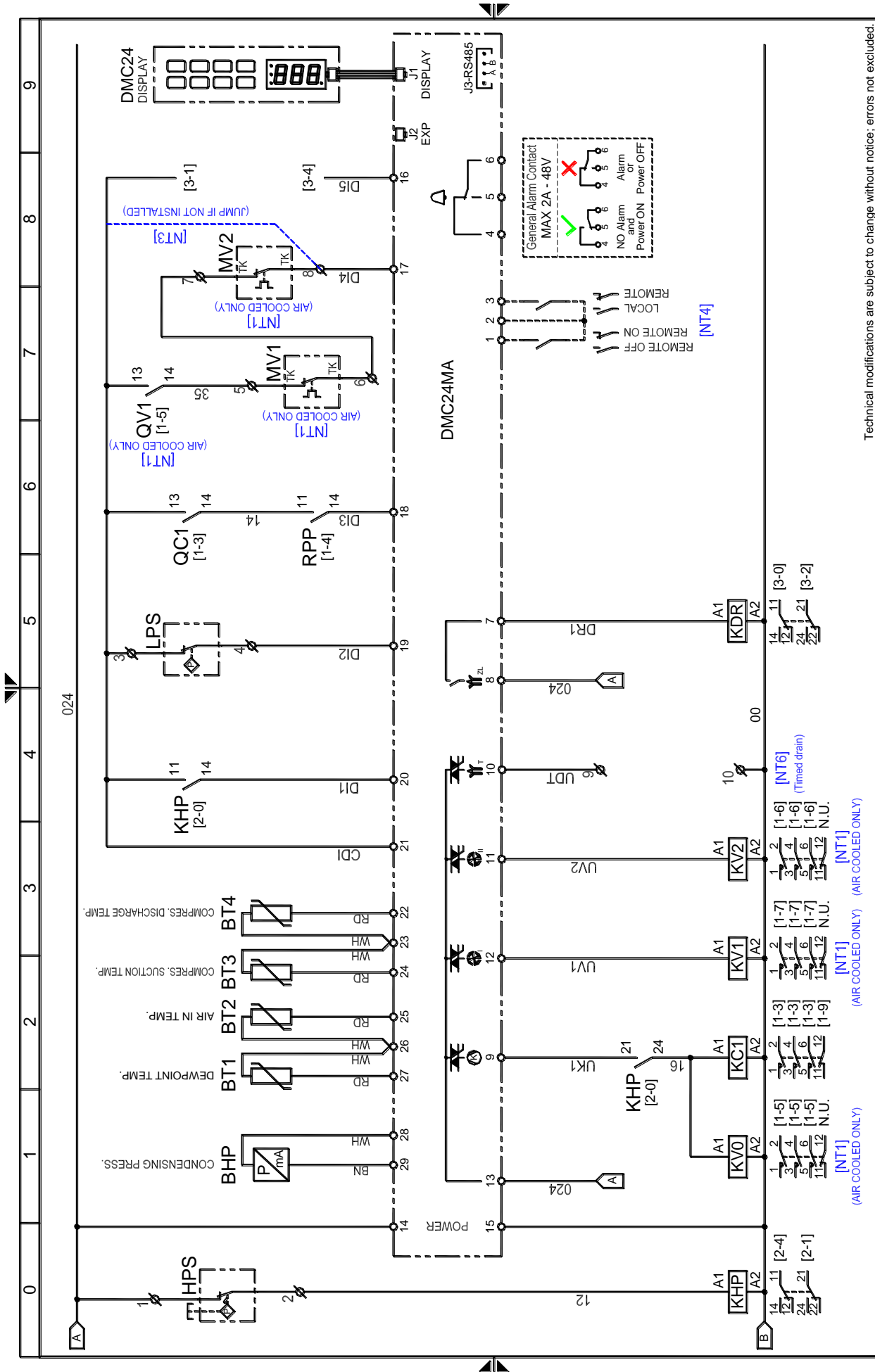

Technical modifications are subject to change without notice; errors not excluded.

Drawing no.: **FRACT-F5478QCDD002**
 Rev. **01**
 Note: .
 Sheet **02** of **04**

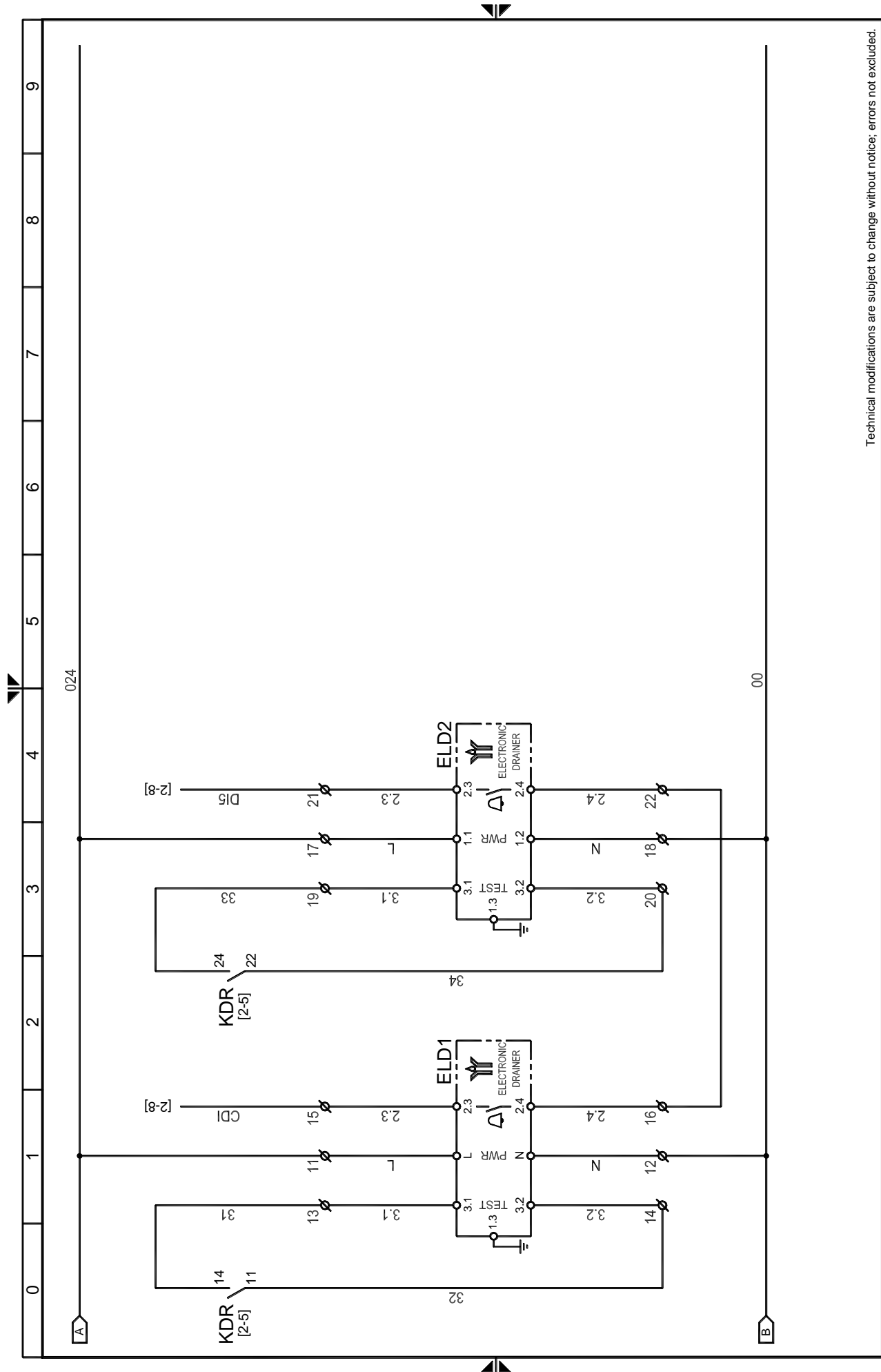

Technical modifications are subject to change without notice; errors not excluded.

Drawing no.: **FRACT-F5478QCD002** Rev. **01**

Note: **Sheet 03 of 04**

9.3.8 SACT 3000 – 5000 Sheet 1 of 6

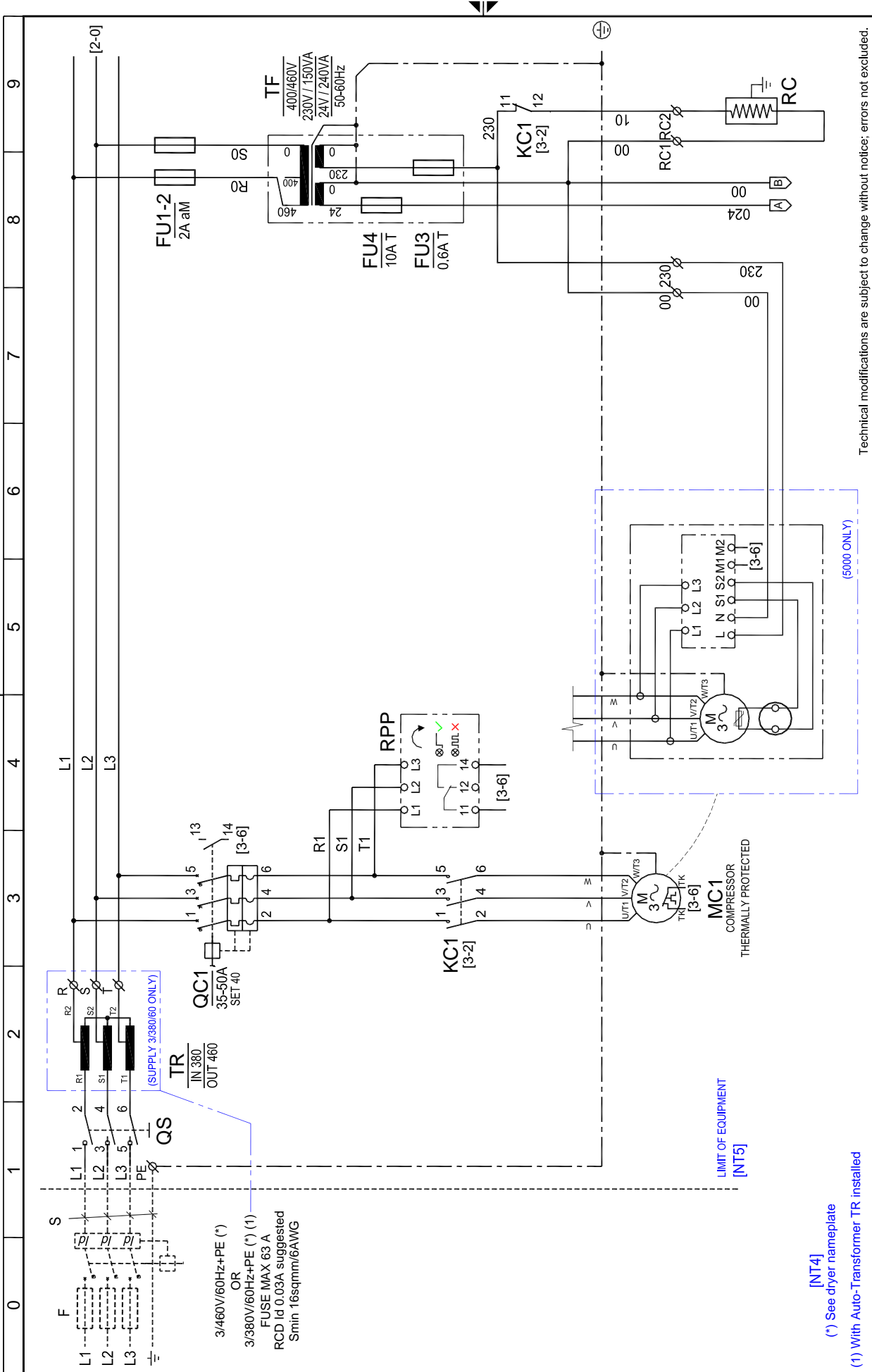

Technical modifications are subject to change without notice; errors not excluded.

Rev.

00

FRACT-UF5478QCDD003

Note :

Sheet 01 of 06

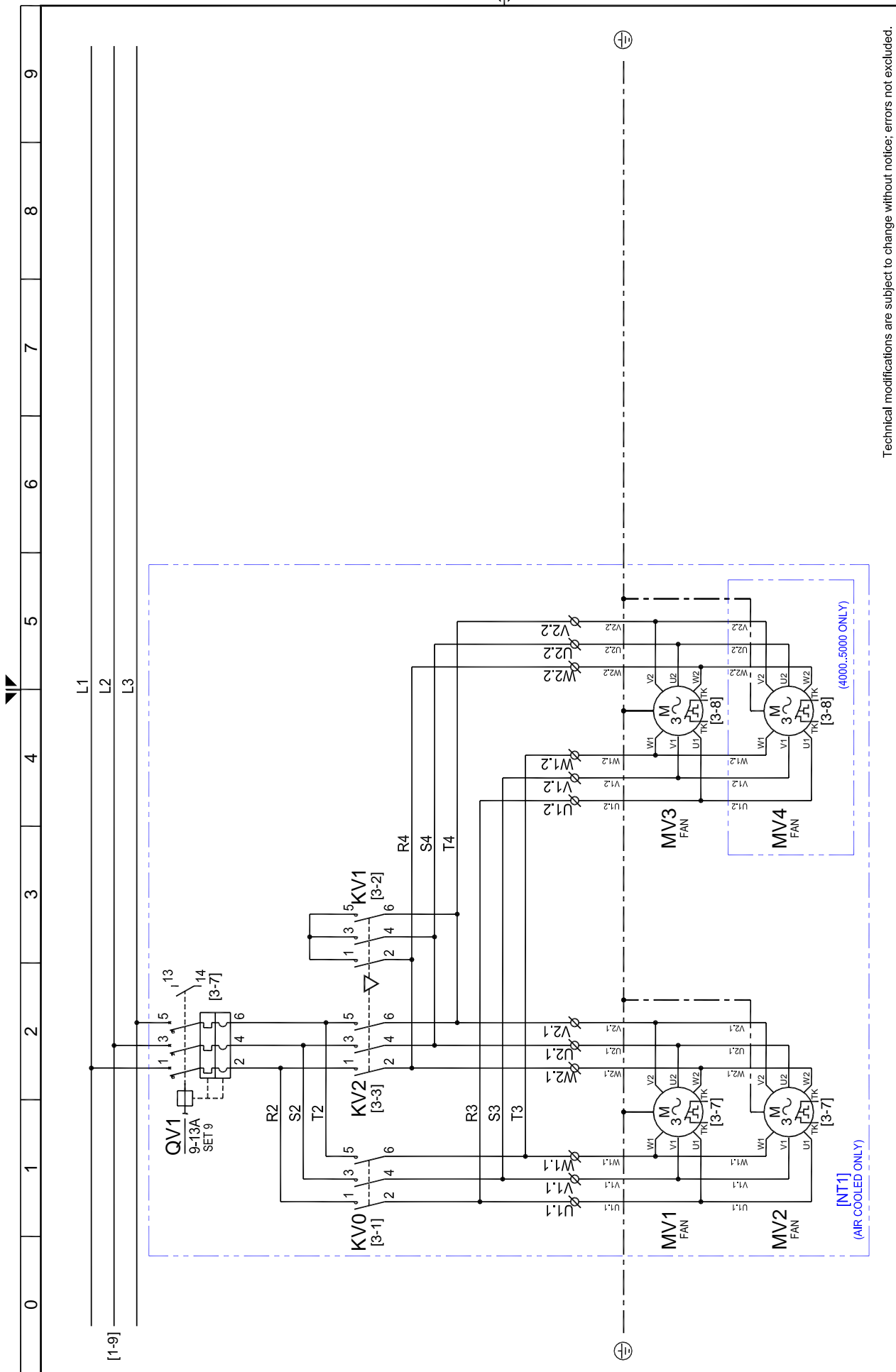

Technical modifications are subject to change without notice; errors not excluded.

Rev.

FRACT-UF5478QCD003 00

Note :

Sheet 02 of 06

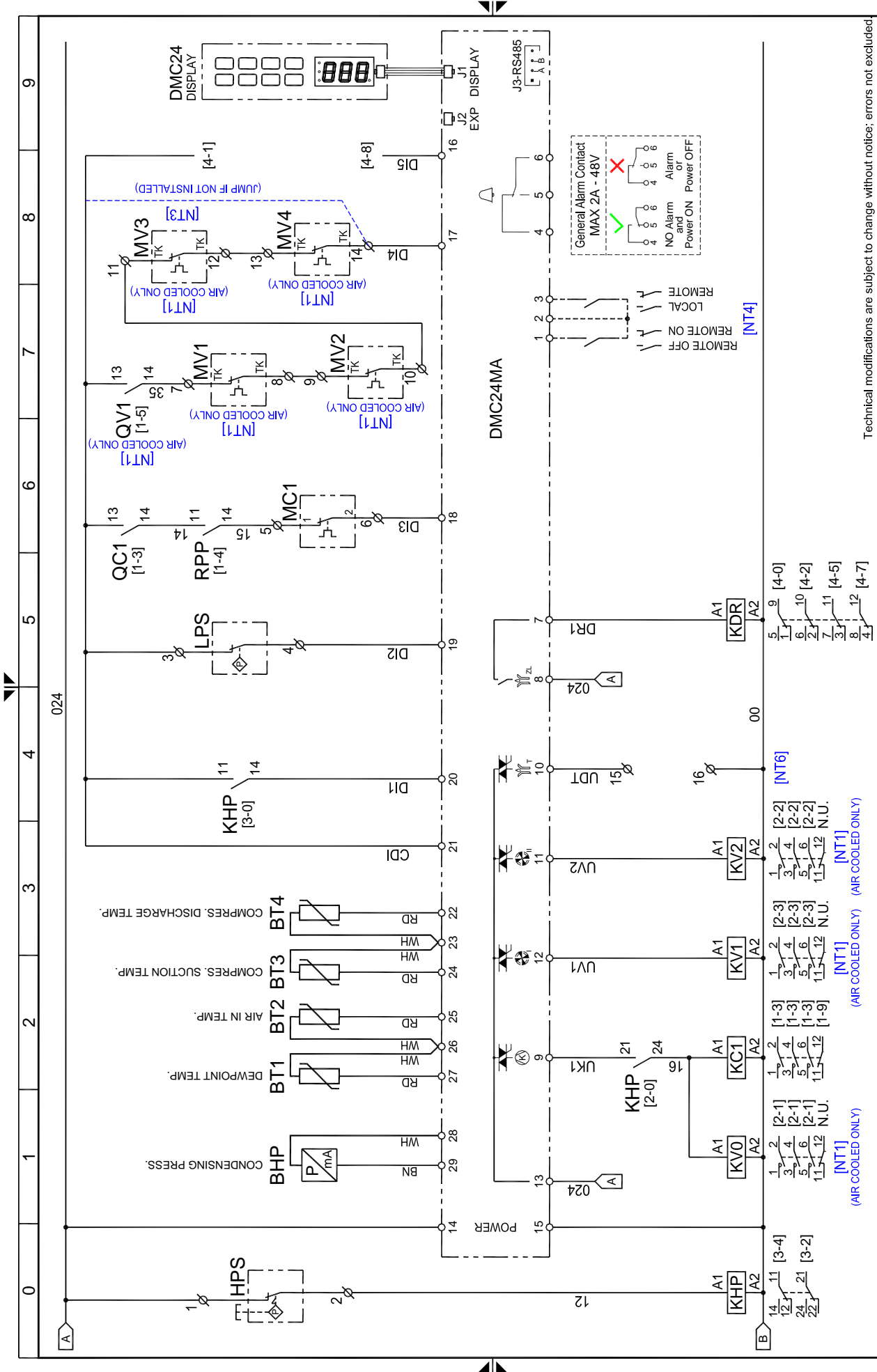

Technical modifications are subject to change without notice; errors not excluded.

Rev.

00

FRACT-UF5478QCDD003

Note :

Sheet 03 of 06

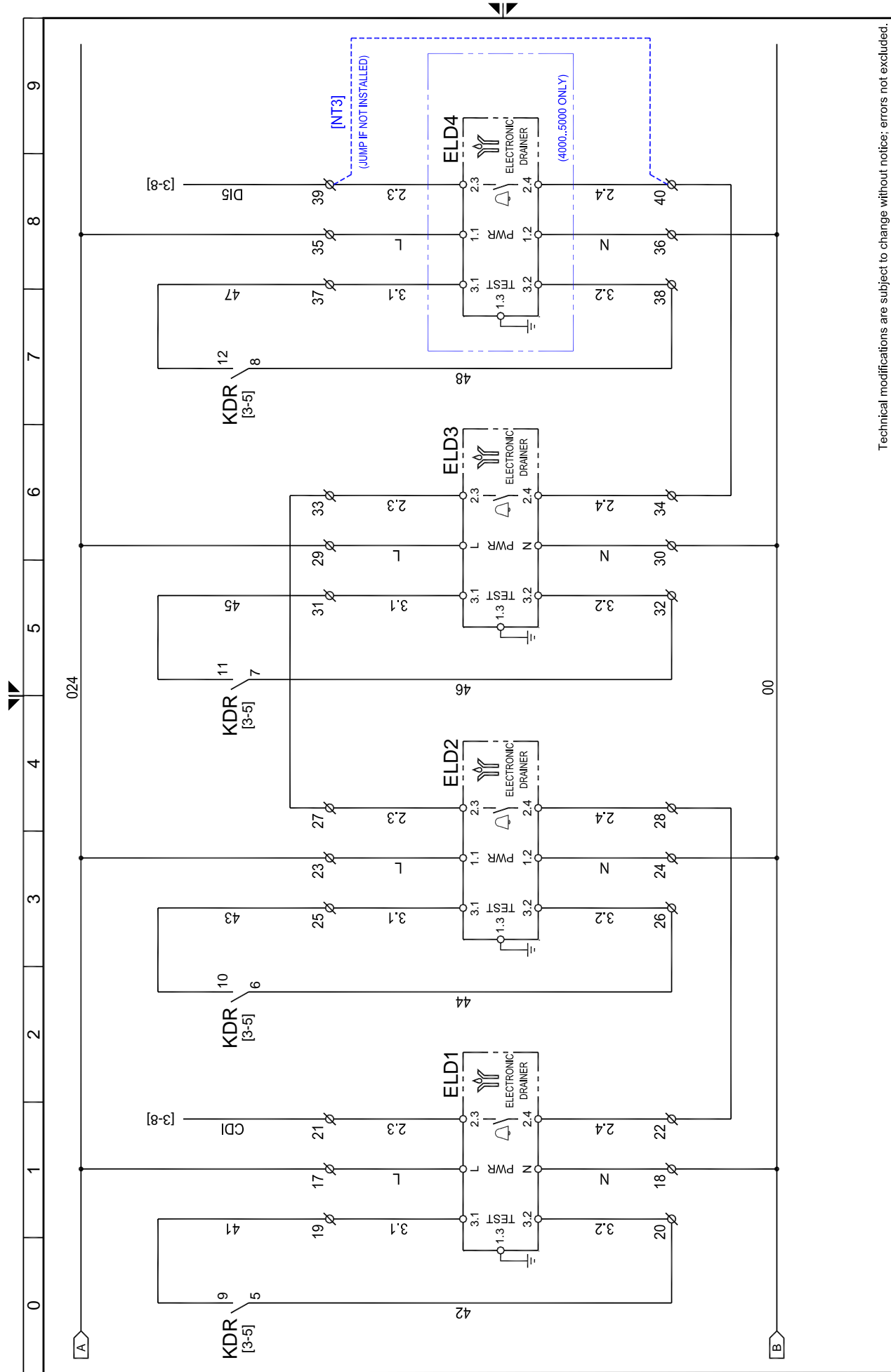

Technical modifications are subject to change without notice; errors not excluded.

Rev.

00

Drawing no. : **FRACT-UF5478QCD003**

Note : -

Sheet 04 of 06

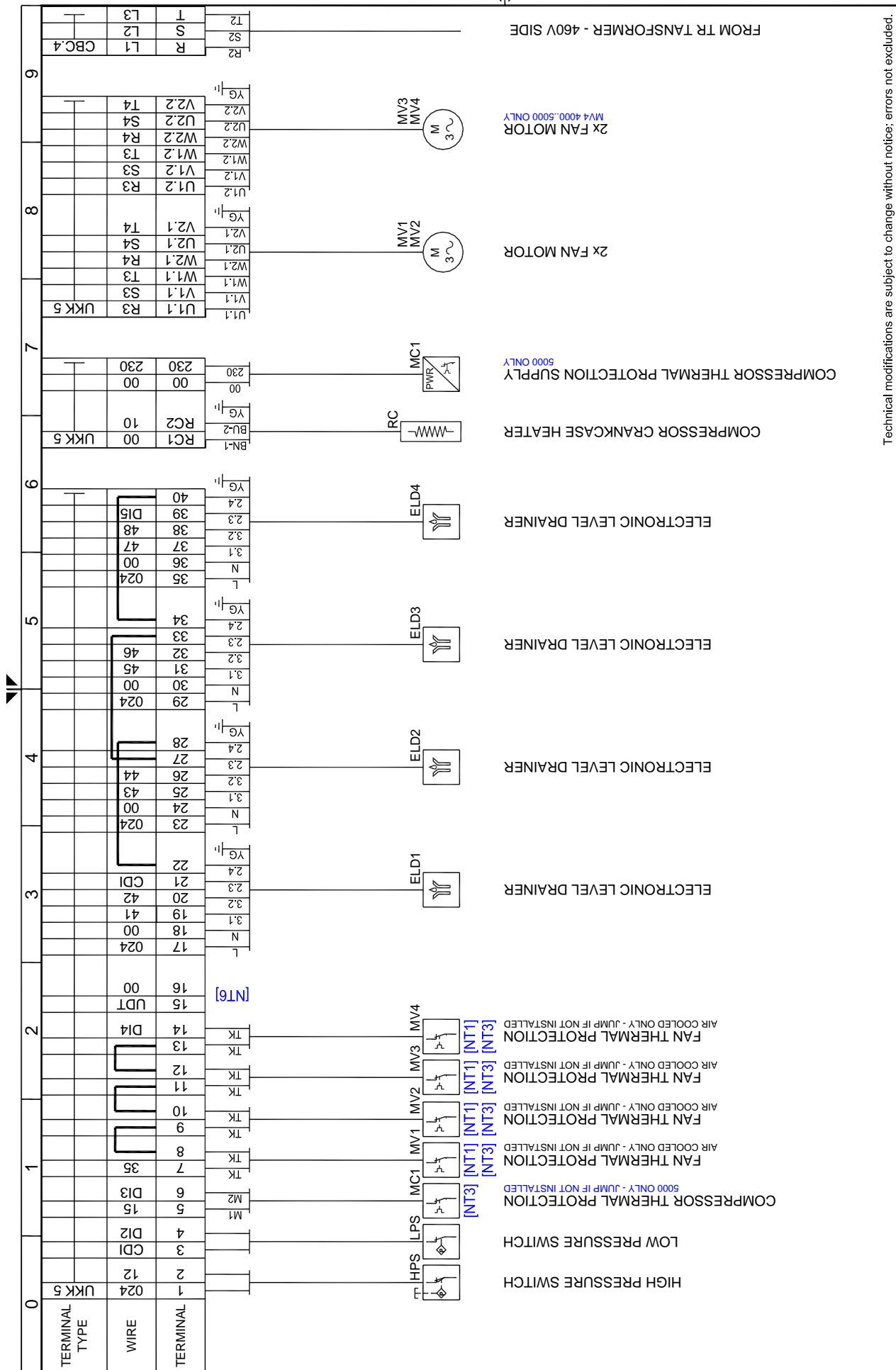

Technical modifications are subject to change without notice; errors not excluded.

Drawing no. : **FRACT-UF5478QCD003**
 Rev. **00**
 Note :

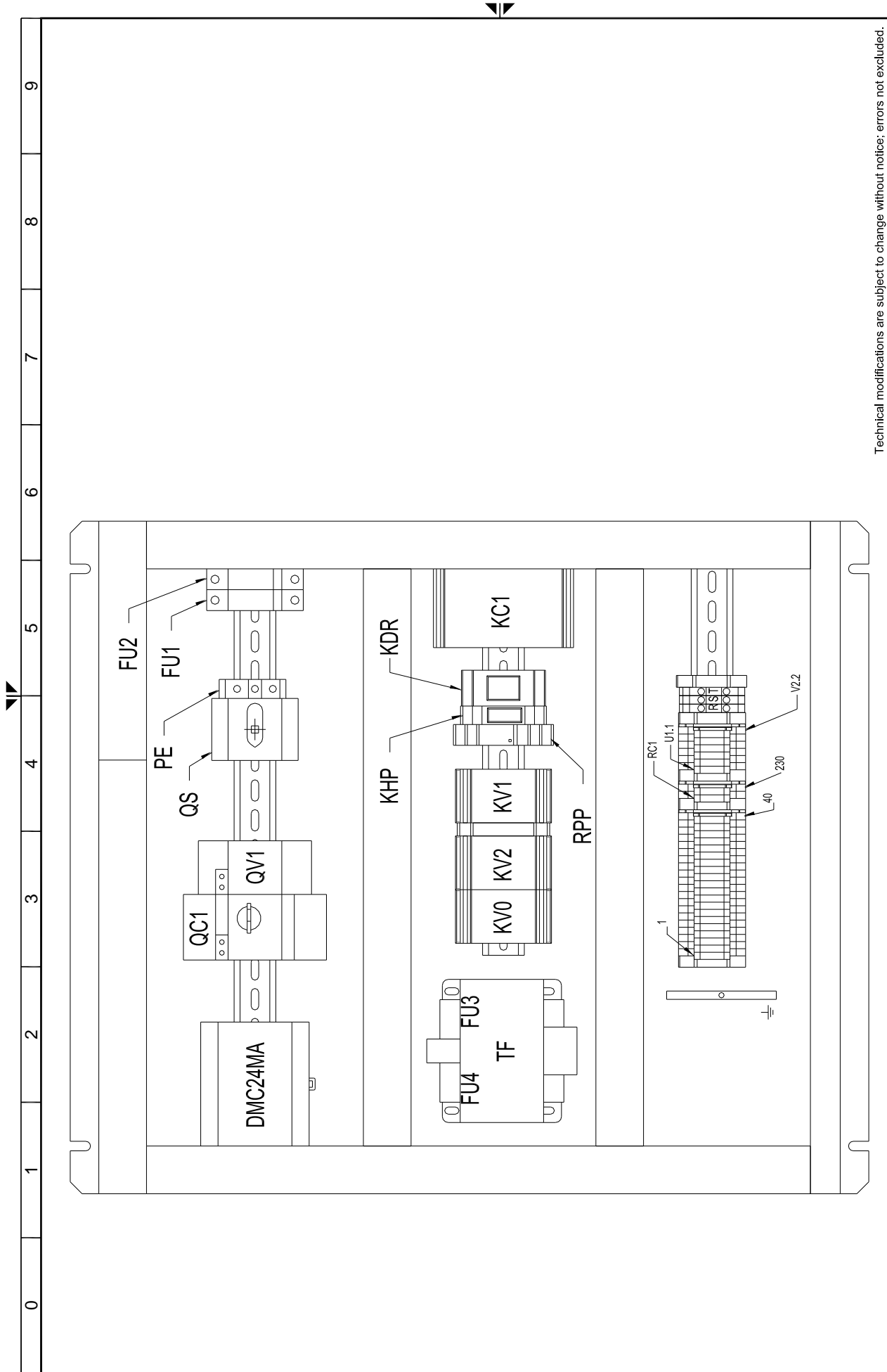

Technical modifications are subject to change without notice; errors not excluded.

Drawing no. : FRACT-UF5478QCD003

Rev. 00

Note : -

Sheet 06 of 06

10 Blank pages

SERVIÇOS E
ATENDIMENTO
AO CLIENTE



ATENDIMENTO TÉCNICO BRASIL
0800 474141
de segunda a sexta-feira, das 8h às 18h

PEÇAS ORIGINALS
Consulte a Rede de Assistência Técnica Autorizada

 SCHULZ S.A.
Rua Dona Francisca, 6901
Phone: 47 3451.6000
Fax: 47 3451.6060
89219-600 - Joinville - SC
schulz@schulz.com.br
www.schulz.com.br



INFORMACIÓN TÉCNICA
TECHNICAL INFORMATION
export@schulz.com.br
+55 47 3451 6252

PIEZAS ORIGINALES
Consulte Distribuidor Autorizado

ORIGINAL
REPLACEMENT PARTS
Contact Authorized Distributor

 SCHULZ OF AMERICA, INC.
3420, Novis Pointe
Acworth, GA 30101
Phone # (770) 529.4731
Fax # (770) 529.4733
sales@schulzamerica.com
www.schulzamerica.com

RECICLÁVEL RECYCLABLE



04/14

025.1018-0 Impresso Itália

74MD0001C5-EN_00