

Vertical Air Receivers with Platform & Feet or Basing 30 - 120 Gallons

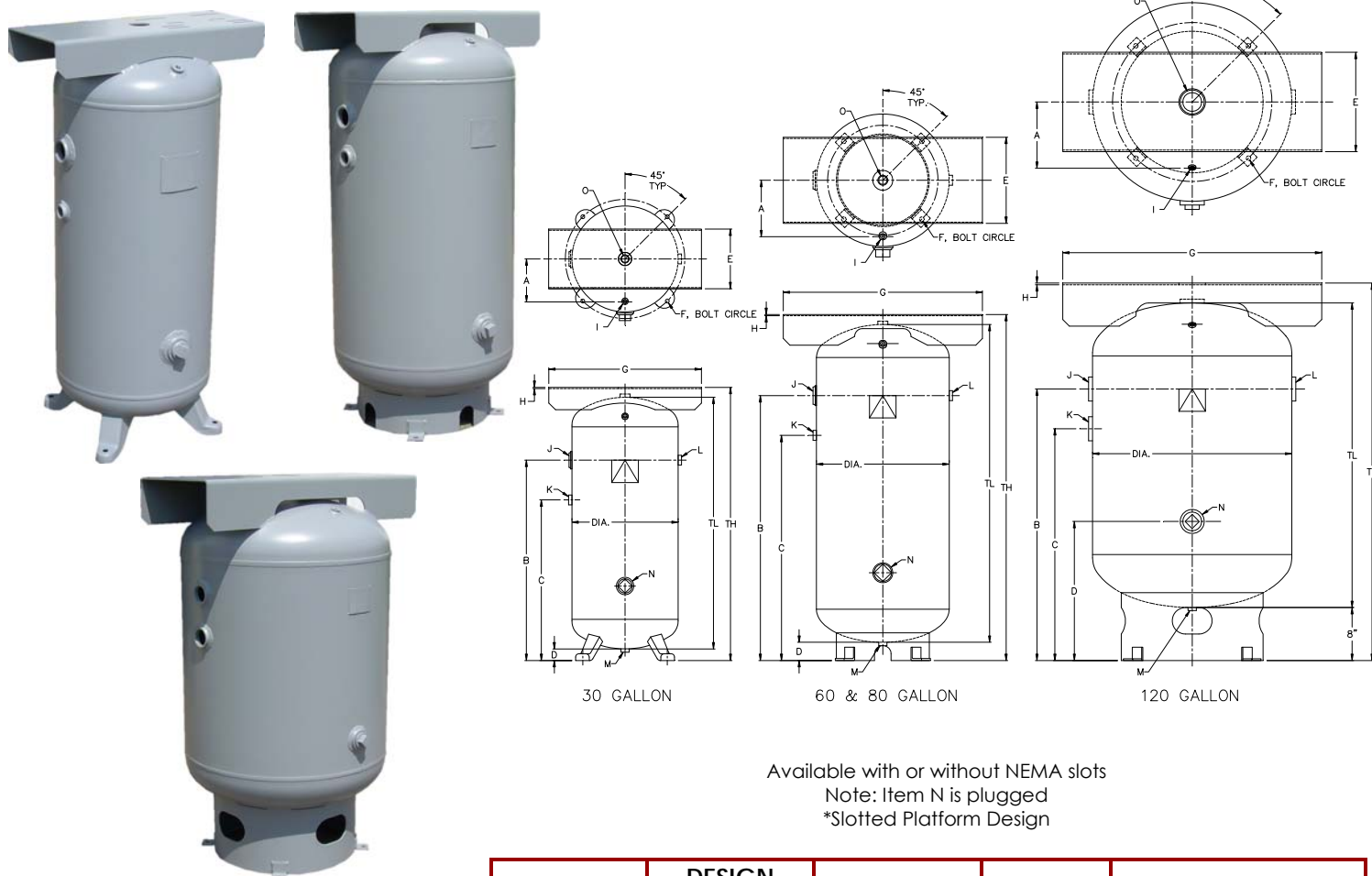

Available with or without NEMA slots
 Note: Item N is plugged
 *Slotted Platform Design

GAL	DESIGN PRESSURE	PART #	WT. (LBS)	*NEMA SLOTS
30	200 PSI	A21316038200	101	NO SLOTS
		*A21316038201		56, 182T, 184T, 213T
60	200 PSI	A21320048200	166	NO SLOTS
		*A21320048201		56, 182T, 184T, 213T, 215T
80	200 PSI	A21324048200	211	NO SLOTS
		*A21324048201		56, 182T, 184T, 213T, 215T
120	200 PSI	A21430046200	470	NO SLOTS
		*A21430046201		184T, 213T, 215T, 254T

DESCRIPTION				DIMENSIONS (INCHES)								OPENINGS (NPT)							
GAL	DIA	TL	TH	A	B	C	D	E	F	G	H	I	J	K	L	M	N	O	
30	16	38	41 7/8	6 1/2	31 1/8	25 1/8	2 5/8	9	18	23	3/16	1/4	1 1/2	3/4	3/4	1/2	1 1/2	3/4	
60	20	48	52 1/4	8 1/2	40	34	2 3/4	13	16 5/8	30	3/16	1/4	2	3/4	3/4	1/2	2	3/4	
80	24	48	53 1/4	9	40 5/16	35 5/16	3 3/16	13	20 5/8	30	3/16	1/4	2	1 1/4	1 1/4	1/2	2	1 1/4	
120	30	46	57	10	41	35	21	15	24	39	1/4	1/4	2	2	2	1/2	2	2	