

TECHNICAL DATA

MODEL	DISPLACEMENT cfm	MAX. PRESSURE psig	RPM	MOTOR hp	BELT	MOTOR PULLEY		OIL CAP.		WEIGHT lbs	DISCHARGE SIZE
						2 POLES		l	qt.		
MSL 10 ML	10	120	2,185	2	1-3VX	inch	mm	0.27	0.28	22.5	3/8" NPT
						4.92	125				

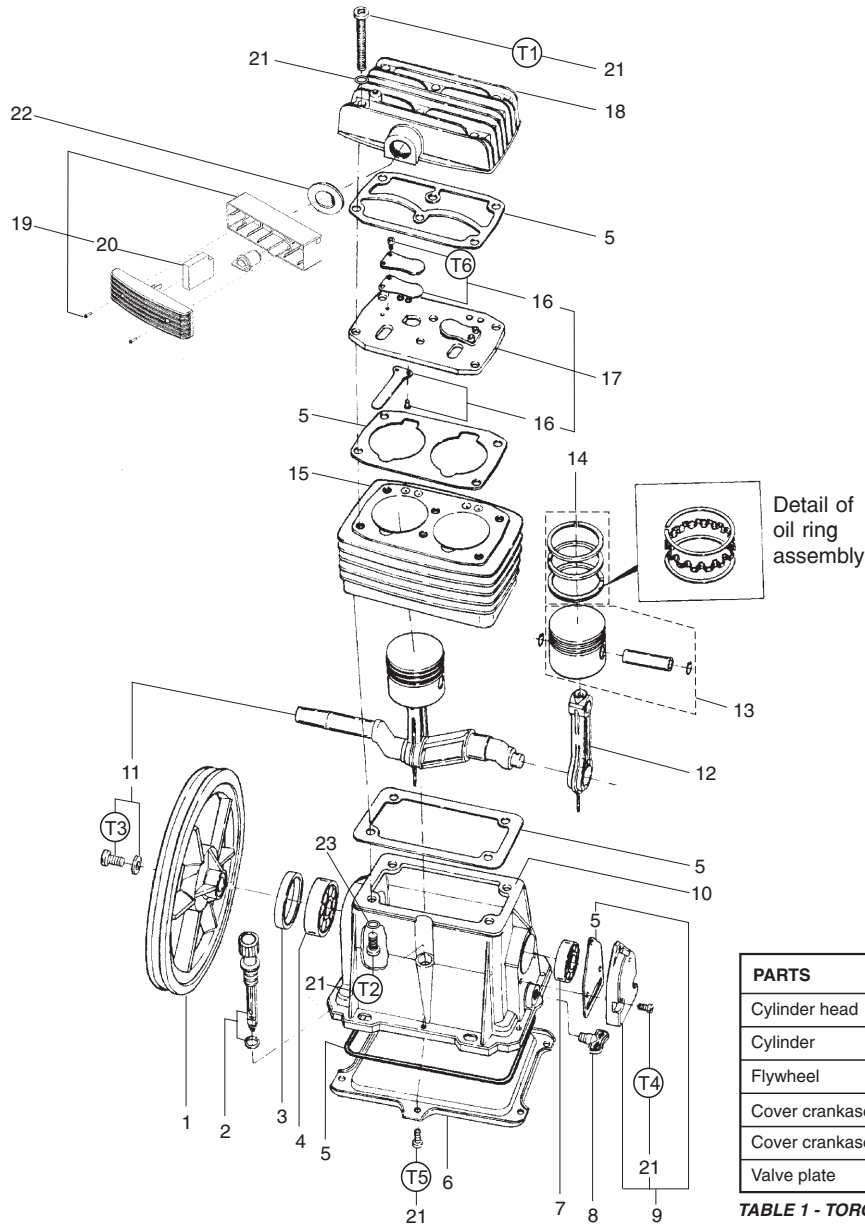

PARTS	POSITION	BOLT	lbf.in	N.m
Cylinder head	(T1)	M6 x 1.0 x 50 Type Allen	105	12.0
Cylinder	(T2)	M8 x 1.25 x 20 Philips	213	24.0
Flywheel	(T3)	M6 x 1.0 x 18 Hexagonal	74	8.3
Cover crankase	(T4)	M3 x 0.5 x 20 Crack	4.4	0.5
Cover crankase	(T5)	M5 x 0.8 x 12 Philips	49.8	5.6
Valve plate	(T6)	M3 x 0.5 x 6 Type Allen	19	2.2

TABLE 1 - TORQUE ESPECIFICACION

BARE PUMP PARTS

No.	CODE	DENOMINATION	QTY	No.	CODE	DENOMINATION	QTY
1	709.1095-0	Flywheel	01	12	709.1089-0	Connecting rod	02
2	809.0737-0	Oil level dipstick	01	13	016.0047-0	Ø 2" Piston	02
3	023.0299-0	Oil seal	01	14	830.0823-0	Ring kit (kit is for 1 cylinder)	02
4	019.0068-0	6303 Bearing	01	15	709.1094-0	Cylinder	01
5	830.0832-0/NA	Gasket (kit)	01	16	830.0825-0	Valve plate (kit)	01
6	709.1100-0	Crankcase lower cover	01	17	830.0839-0	Valve plate	01
7	019.0065-0	6202 Bearing	01	18	709.1627-0	Aluminum cylinder cover	01
8	028.0140-0	Oil drain plug	01	19	809.0793-0	Air filter	01
9	830.1106-0	Crankcase front cover (kit)	01	20	007.0122-0	Filter element	01
10	709.1097-0	Crankcase	01	21	830.0844-0	Bolt (kit)	01
11	830.0830-0	Crankshaft (kit)	01	22	023.0286-0/NA	Thermal protection washer	01
				23	001.0023-4	5/16" Lock washer	04

DIMENSIONS

MSL 10 ML

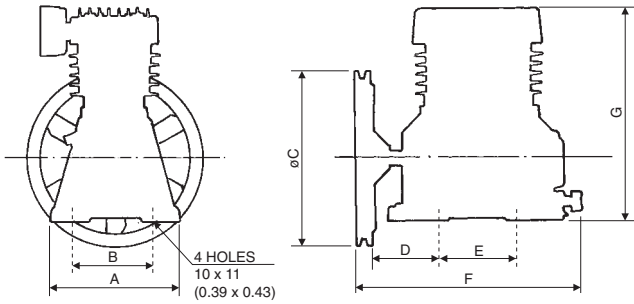

	A	B	C	D	E	F	G
mm	146	120	200	73	90	260	250
inch	5.74	4.72	7.87	2.87	3.54	10.23	9.84

INSTALLATION AND OPERATION INSTRUCTIONS

INSTALLATION AND LOCATION

1. Installation: Install the compressor in a covered, well ventilated area, free of dust, toxic gases, humidity or any other kind of pollution. The compressor should be located no closer than 32" (800mm) from a wall or any other obstacle that could interfere with the air flow through the fan. This distance will also make maintenance easier. Place the compressor on a leveled surface. Rotation of the flywheel must be in the direction of the arrow cast into the flywheel. The maximum ambient temperature recommended while working is 104°F or 40°C. If necessary, install an exhaust fan to guarantee fresh air and to dissipate heat.

Before making the electrical connections, check oil level and top-up lubricating oil. For type of oil, see table at the end of these instructions.

2. Electrical connection: The country's valid electrical standards must be followed regarding Low Voltage Electrical Installation.

OPERATION

1. Initial start procedure: Before turning on the compressor, check the crankcase oil level. It must be in the middle of the oil level sight or between the dipstick's maximum and minimum marks. As to the type of oil to be used and the recommended change intervals, check at "Lubrication" and as to its volume, check the Technical Data Table.

2. Start: Turn on the electrical start key and let your compressor run for about 10 (ten) minutes, what will keep the tank's internal pressure or compressed air around 20 psig. This will optimize a homogeneous lubrication of the parts.

LIMITED WARRANTY

All component parts on your SCHULZ compressor are warranted to be free of defects in workmanship and material for a period of one year. Transportation charges are responsibility of the purchaser. This warranty extends to the original purchaser of the compressor only.

There are no express warranties except as contained in this limited warranty statement and implied warranties, including those of merchantability and fitness for a particular purpose, are limited to the period of warranty.

Our liability is limited solely to replacement of nonconforming parts as set forth herein and does not include any liability for any incidental, consequential, or other damages of any kind. This warranty gives you specific legal rights, and you may also have other rights that vary from state to state.

SCHULZ

Schulz of America, Inc.
 3420 Novis Pointe
 Acworth, GA 30101
 Phone # (770) 529-4731 / 32
 Fax # (770) 529-4733
 sales@schulzamerica.com
 www.schulzamerica.com

MAINTENANCE

WARNING

Turn off power before servicing and be sure the air tank is unloaded. These instructions are based on normal operating conditions. If the compressor is located in an exceedingly dusty area, increase the frequency of all inspections.

DAILY

- Inspect the compressor visually.
- Check oil level and add some if necessary, before turning the compressor on.
- Drain moisture from the piping system.
- Be sure there is no excessive or unusual vibration or noise.

WEEKLY

- Remove and clean intake air filters; do not wash the filter element.
- Check V-belts for tightness. Belt tension should be adjusted to allow approximately 5/32" (4.0 mm) deflection with normal thumb pressure.
- Clean cylinders externally, cylinder head, motor, fan blade, tubing, and tank.
- Safety valve should be tested manually to see if it is working properly.

MONTHLY

- Check entire system for air leakage around fittings, etc by using water and soap lather.
- Check the pressure switch operation.
- Check for oil contamination and change it if necessary.

QUARTERLY

- Change the air filter element every 300 working hours or quarterly. (Whichever occurs first).
- Fasten cap bolts and nuts as required. (See Table 1)
- Change oil more frequently if compressor is located in a very dirty environment.
- **WHILE RUNNING IN A PERIOD OF ABOUT 100 WORKING HOURS THE OIL LEVEL SHOULD BE CAREFULLY CHECKED.**

ANNUALLY

- Test and calibrate the pressure switch, pressure gauge and safety valve according to their own technical standards. These parts must be removed from the tank and pump to be tested.
- Inspect and clean the suction and discharge valve(s) plate(s) every 1,000 (one thousand) working hours (whichever occurs first), located between the cylinder and its cover and, if necessary, replace it (them) according to the operation conditions.

LUBRICATION

- The first oil change should be made after 8 hours of operation.
- The second oil change after 40 hours of operation.
- The third and following exchanges should be made after 200 hours of operation, or 60 (sixty) days, whichever occurs first.

NOTE:

Heavy Duty and multi-viscous oils are not adequate for Schulz air compressor's lubrication. The same applies to oils that tend to emulsify.

We recommend good industrial oil for air compressors, with rust and oxidation inhibitors and high viscosity level (from 90 to 95), SAE or ISO, as indicated in the table below:

RECOMMENDED LUBRICANT OILS FOR SCHULZ AIR PUMPS

AMBIENT TEMPERATURE °F (°C)		
Below 32 °F Below 0 °C	32 °F to 68 °F 0 °C to 20 °C	68 °F to 104 °F 20 °C to 40 °C
SAE 10W or ISO 32	SAE 20W or ISO 68	SAE 30 or ISO 100

DISTRIBUTOR

